



Échelon™ Series



Installation Guide

2015WC Wine Captain® and 2015WCOL Wine Captain® with Overlay

www.U-LineService.com

Phone (414) 354-0300 • FAX (414) 354-7905
Service & Parts Tech Lines Phone (800) 779-2547 • FAX (414) 354-5696
OnlineService@U-Line.com

©2005 U-Line Corporation
02/2005

Contents

Exterior Cleaning 4
 Cut-Out Dimensions 4
 Product Dimensions 5
 Door Swing/Clearances Information 5
 Reversing the Door..... 5
 Other Site Requirements 6
 Side-By-Side Installation Instructions 7
 Adding a Final Finish Coat to Wood Trim..... 7
 Staining Wood Trim a Different Color 8
 Overlay Frame 8
 Checking Door Alignment 12
 Adjusting Door Alignment 12
 Electrical Specifications 13
 Leveling Information 13
 Installation Tip 13
 Anti-Tip Bracket Installation 14
 Installation Troubleshooting 15
 Initial Start-Up 15
 Start-Up Troubleshooting 15
 Service Information 16

1 Follow Safety Precautions

IMPORTANT

PLEASE READ all instructions completely before attempting to install or operate the unit.

- This unit requires connection to a grounded (three-prong), polarized receptacle that has been placed by a qualified electrician in accordance with applicable electrical codes.

Safety Alert Definitions

Safety items throughout this guide are labeled with a Danger, Warning or Caution based on the risk type:

⚠ DANGER

Danger means that failure to follow this safety statement will result in severe personal injury or death.

⚠ WARNING

Warning means that failure to follow this safety statement could result in serious personal injury, or death.

⚠ CAUTION

Caution means that failure to follow this safety statement may result in minor or moderate personal injury, property or equipment damage.

General Precautions

Use this appliance for its intended purpose only and follow these general precautions along with those listed throughout this guide:

WARNING

SHOCK HAZARD — Electrical Grounding Required.

- **Keep the unit unplugged throughout installation except during testing.**
- **Never remove the round grounding prong from the plug and never use a two-prong grounding adapter.**
- **Never use an extension cord to connect power to the unit.**
- **Always keep your working area dry.**

CAUTION

- Use care when moving and handling the unit. Use gloves to prevent personal injury from sharp edges.
- Do not lift the unit by the door or door handle.
- Do not install the unit behind closed doors or in any way that would obstruct airflow to the front grille, which may cause the unit to malfunction.

2 Inspect and Plan

You have received a carton containing your 2015WC or 2015WCOL Wine Captain® with a package inside containing a User Manual, a Product Registration Card and an Anti-Tip Bracket Installation Kit. 2015WCOL units are shipped with a cardboard-wrapped door and an additional package of hardware. Complete and mail the Product Registration Card or register online at www.U-LineService.com. Once your unit is installed, keep the User Manual and this Installation Guide in a safe place for future reference.

2015WC units are Black, White or Stainless Steel. Black and White units have a reversible door with a slightly contoured handle across the top. Stainless Steel units are covered with a protective coating and have been ordered left- or right-hand hinged. The Stainless doors are not reversible.

2015WCOL units are Black with an unattached door that requires the construction of a 3/4-inch thick wood overlay frame. You must determine left- or right-hand opening before construction.

All units come with maple trim wine racks that can be finished or stained. Please carefully follow the directions that apply to your unit and your intended design.

Tools/Materials Required

- 7/64" Allen wrench (included in 2015WCOL hardware)
- Screwdrivers — slotted and Phillips head
- Sandpaper; low odor, water clean up, quick drying finish; tack cloth and, if desired, water-based wood stain and synthetic foam brush
- 3/4-inch overlay frame material, cutting tools, drill and bits (2015WCOL units)

Inspection

Unwrap and inspect the unit on a flat, level surface capable of supporting its entire weight.

Removing Protective Coating

(Stainless Steel Units Only)

When inspecting/installing a Stainless Steel unit, the protective coating covering the unit must be removed first. Start at a corner of the unit/door and pull back the protective coating to remove it from the unit/door.

After all the protective coating has been removed from the unit/door, clean all Stainless Steel surfaces with Claire Stainless Steel Polish and Cleaner or comparable product or a mild detergent and warm water solution and soft cloth. Do NOT use abrasive cleaning agents.

Note: If cleaning with mild detergent and warm water solution and soft cloth, the unit MUST be treated with Claire Stainless Steel Polish and Cleaner or comparable product to prevent discoloration.

Exterior Cleaning

(As Required)

Black and White Models:

- The door, grille and cabinet may be cleaned with a mild detergent and warm water solution. Do not use solvent-based or abrasive cleaners. Use a soft sponge and rinse with clean water. Wipe with a soft, clean towel to prevent water spotting.

Stainless Steel Models:

- Stainless steel models can discolor when exposed to chlorine gas, pool chemicals, salt water or cleaners with bleach.
- Keep your stainless steel unit looking new by cleaning with a good quality all-in-one stainless steel cleaner/polish on a monthly basis. For best results use Claire Stainless Steel Polish and Cleaner, which can be purchased from U-Line Corporation. (The part number is 173348.) Comparable products are acceptable. Frequent cleaning will remove surface contamination that could lead to rust. Some installations may require cleaning on a weekly basis.
- **Do not clean with steel wool pads.**
- **Do not use cleaners that are not specifically intended for stainless steel (this includes glass, tile and counter cleaners).**
- If any surface discolors or rusting appears, clean it quickly with Bon-Ami or Barkeepers Friend Cleanser and a non-abrasive cloth. Always clean in the direction of the grain. Always finish this process with Claire Stainless Steel Polish and Cleaner or comparable product to prevent further problems.
- **Use of abrasive pads such as Scotchbrite will cause the graining in the stainless to become blurred.**
- Rust that is allowed to linger can penetrate into the surface of the stainless steel and complete removal of the rust may not be possible.

3 Prepare Site

Your U-Line product has been designed for either free-standing or built-in installation. When built-in, your unit does not require additional air space for top, sides or rear. However, the front grille must NOT be obstructed and clearance is required for electrical connection in the rear.

Note: Unit can NOT be installed behind a closed cabinet door.

Cut-Out Dimensions

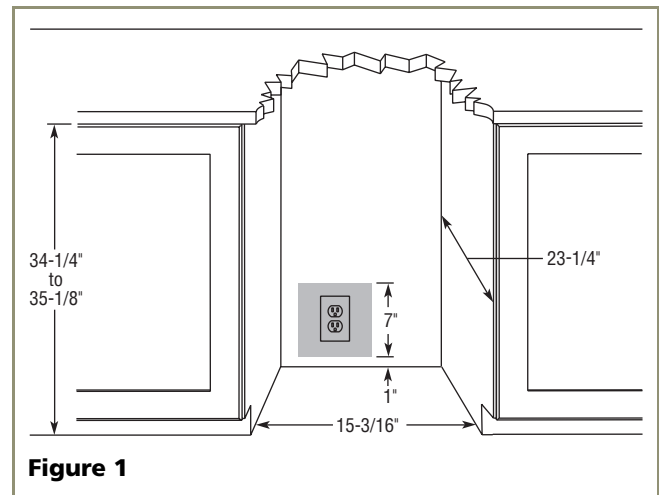

Figure 1

Follow the cut-out drawing in **Figure 1**. The 15-3/16" width allows 1/4" for ease in installation and removal of the unit. 24" is the counter depth in most installations. The unit is 23-1/4" deep including the handle on Black and White 2015WC models, 23-1/4" deep including the wood overlay frame on 2015WCOL models and 23-1/4" deep including the door and *not* the handle on Stainless Steel models (see **Figure 2**).

Product Dimensions

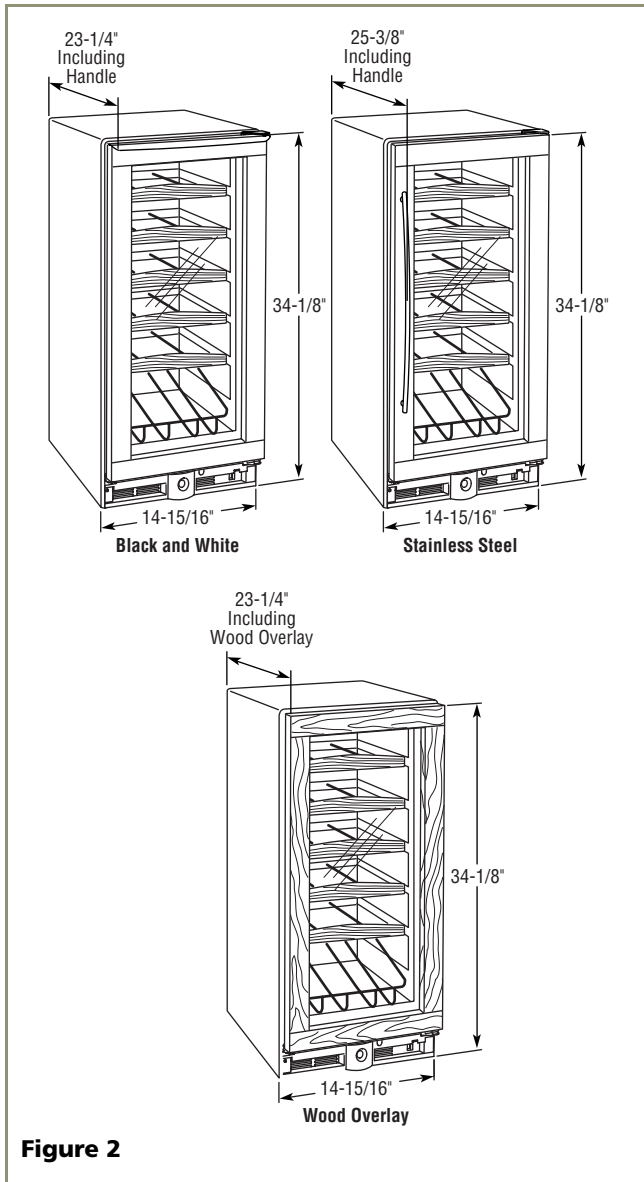

Figure 2

Please note that the unit has adjustable feet that can add one additional inch to height during leveling or to match adjacent cabinets (see **Figure 29** on **Page 13**).

Door Swing/Clearances Information

Black, White and Wood Overlay units have a zero clearance for the door to open 90° (see **Figure 3**). Stainless Steel models require a minimum of 2-1/8" door clearance to accommodate the handle if the unit is installed next to a wall or similar type of structure.

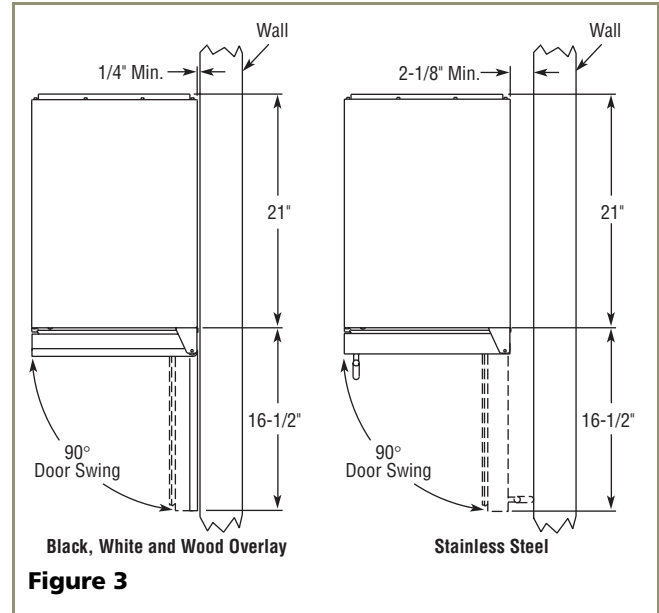

Figure 3

Reversing the Door

(Black and White Units Only)

All U-Line units (except Stainless Steel models) may be left- or right-hand opening. The door opening is easily reversed by moving the hinge hardware to the opposite side. The top hinge hardware will be used on the bottom of the other side and the bottom hinge hardware will be used on the top of the other side (see **Figure 4**).

To reverse the door:

1. Remove top hinge screw pin from door (7/64" Allen wrench or Phillips screwdriver, depending on your unit's construction) (see **Figure 5**). Remove door by tilting forward and lifting off bottom hinge pin.

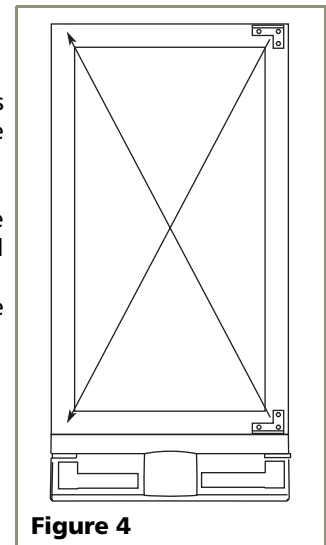

Figure 4

- Remove plastic screw plugs (3 each, top and bottom) from new hinge location. Do not discard (see **Figure 6**).

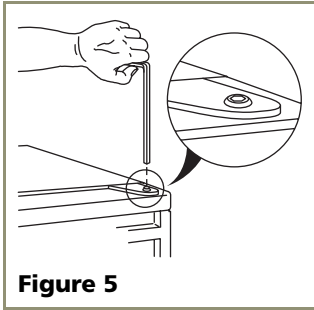

Figure 5

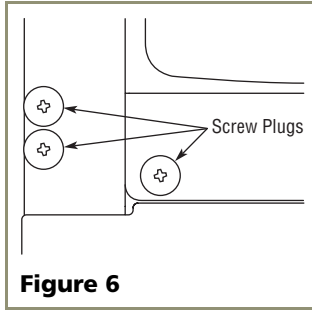

Figure 6

- Remove top hinge (3 screws), reinstall hinge screw pin, and remount on opposite side **BOTTOM** (see **Figure 7**).
- Remove the two door closer inserts from the existing bottom hinge and install as shown on the new bottom hinge (see **Figure 8**).

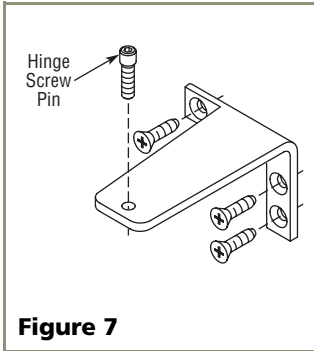

Figure 7

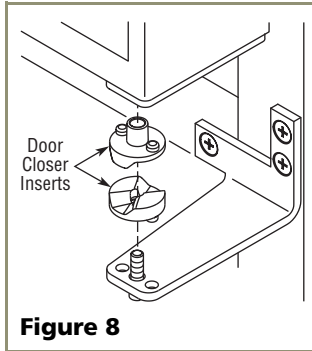

Figure 8

- Remove existing bottom hinge (3 screws) and remount on opposite side **TOP**. Remove hinge screw pin.
- Remove the plastic hole plug from the top of the door to allow the pivot pin to be inserted in the new location. Install the plug into the vacated hole on the opposite side.

- With bottom of door facing up, remove pivot plate (2 screws), flip over, and remount on opposite side of door (see **Figure 9**). Be sure angled side of plate faces center.

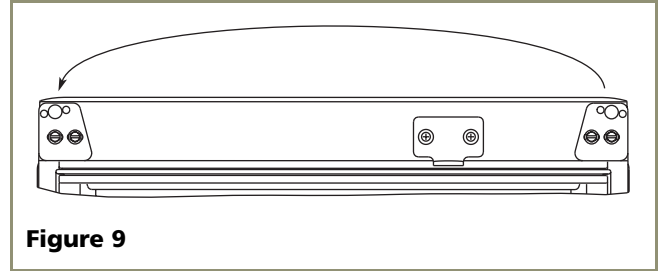

Figure 9

- Holding door upright with top of door tilted forward, place hole of door pivot plate on bottom hinge screw pin (see **Figure 10**).
- Tilt top of door into position in top hinge and install top hinge screw pin.
- Install plastic screw plugs removed in Step 2 in old hinge holes (3 each, top and bottom).

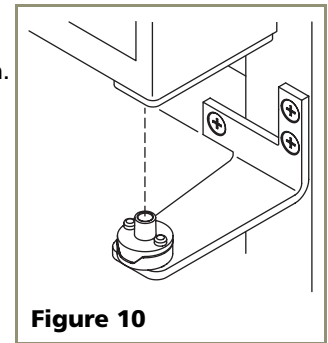

Figure 10

Other Site Requirements

Power Supply

The unit requires a grounded and polarized 115 VAC, 60 Hz, 15A circuit (normal household current). See *Electrical Specifications* on **Page 13**.

Environmental Requirements

The surrounding air temperature must be at least 50°F (10°C) but must not exceed 110°F (40°C). The unit must not be located near heat-generating equipment or in direct sunlight.

Side-By-Side Installation Instructions

For a complete refreshment center, install your 2015WC or 2015WCOL unit beside a U-Line Refrigerator, Ice Maker or Combo Model (see **Figure 11** for typical cut-out). Note that each Side-By-Side Installation will be different.

- Cut-out width for a side-by-side installation is the total of the widths listed under *Cut-Out Dimensions* in each unit's Installation Guide.

For example:

Placing a 2015 Wine Captain® next to a 2015 series unit would require a cut-out width of:
 $15\text{-}3/16" + 15\text{-}3/16" = 30\text{-}3/8"$

Placing a 2015 Wine Captain® next to a 2075 series unit would require a cut-out width of:
 $15\text{-}3/16" + 24\text{-}3/16" = 39\text{-}3/8"$

- No trim kit is required. However, 1/4-inch space needs to be maintained between the units to ensure unobstructed door swing.
- Units must operate from separate, properly grounded electrical receptacles placed according to each unit's *Electrical Specifications*.

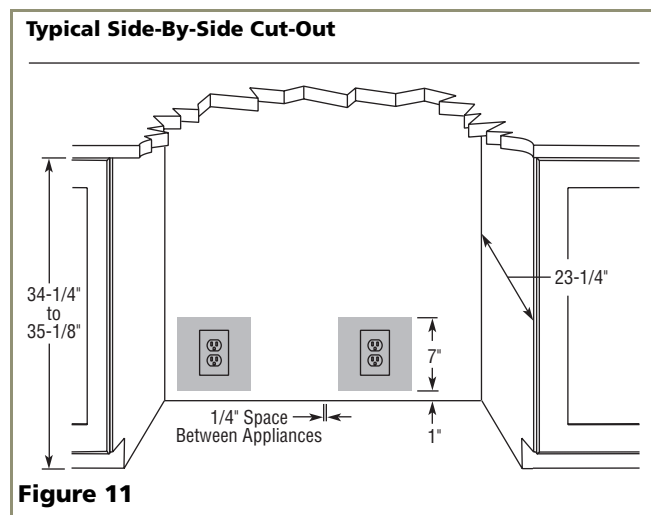

4 Prepare Racks and Door Frame

The U-Line Wine Captain® is equipped with wood-trimmed wine racks that are coated at the factory with a clear vinyl sealer, which will adequately protect the wood in normal usage. A final finish coat was not applied so that the wood trim could be stained to match décor or overlay frame. The trim on the racks may be coated with a final finish or stained.

2015WCOL Models are designed for, and require installation of, an Overlay Frame.

If none of these treatments are to be included in this installation, go on to **5 Adjust Door**.

CAUTION

To prevent permanent damage to the inner liner of the Wine Captain®, the wine rack wood trim **MUST** be removed from the unit for staining and/or finishing. Allow stain/finish to dry thoroughly (at least 24 hours per coat) in accordance with the stain/finish manufacturer's instructions prior to re-installing the wood trim inside the cabinet of the Wine Captain®. Failure to do so may cause the inner liner of the unit to have a permanent odor, which is not covered by the warranty.

Adding a Final Finish Coat to Wood Trim

1. Remove each wine rack by sliding it out and up. See **Figure 12**.
2. Remove and save screws securing wood trim to the racks.
3. Lightly scuff sand the wood trim with 280 grit 3M Tri-M-Ite sandpaper.
4. Remove sanding dust with a tack cloth.
5. Apply a thin coat of Minwax Polycrylic, following container label for directions. Allow to dry 24 hours.
6. Lightly sand, tack and reapply 2 times, if desired.
7. Allow the final coat to dry for 24 hours.
8. Reinstall wood trim to wine racks using screws removed in Step 2.
9. Reinstall wine racks in unit.
10. For 2015WC units, go on to **5 Adjust Door**.

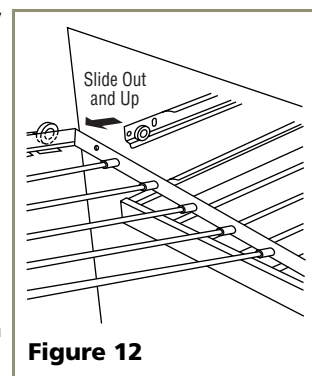

Staining Wood Trim a Different Color

1. Remove each wine rack by sliding it out and up. See **Figure 12**.
2. Remove and save screws securing wood trim to the racks.
3. Apply Minwax Water-Based Wood Stain to wood with a synthetic foam brush. Stain must penetrate approximately 3 minutes. After this period, while stain is still wet, take a stain-dampened rag and remove all excess stain. Wipe in the direction of the grain with medium pressure to achieve the desired stain color.
4. After 2 hours, repeat Step 3.
5. Allow stain to dry for a minimum of 3 hours before finishing.
6. Sand the wood with very fine sandpaper to smooth the surface from the staining process.
7. Remove sanding dust with a tack cloth.
8. Apply a thin coat of Minwax Polycrylic, following container label for directions. Allow to dry 24 hours.
9. Lightly sand, tack and reapply 2 times, if desired.
10. Allow the final coat to dry for 24 hours.
11. Reinstall wood trim to wine racks using screws removed in Step 2.
12. Reinstall wine racks in unit.
13. For 2015WC units, go on to **5 Adjust Door**.

Overlay Frame

(2015WCOL Units Only)

Frame Preparation

An overlay frame covers the door frame to give a built-in appearance. Appropriate hardware and a copy of these instructions will be included in the unit.

IMPORTANT

The thickness of the wood overlay frame must be $\frac{3}{4}$ ". The door frame must not weigh more than 20 lbs.

1. Create an overlay frame to the dimensions shown in **Figure 13**.

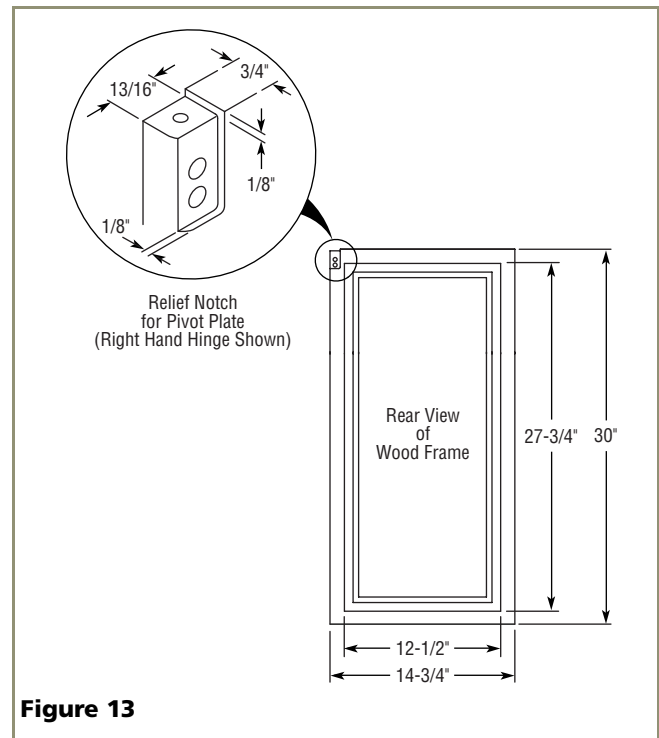

IMPORTANT

Rear View of wood frame for right-hand hinge shown. Use mirror image for left-hand hinges.

2. Typical routing dimensions are shown in **Figure 14**.

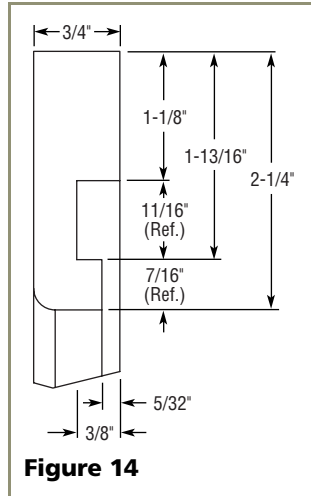

3. Create a relief for pivot plate by cutting notch in top corner and coinciding back corner of overlay frame. Refer to **Figure 15** for exact specifications.

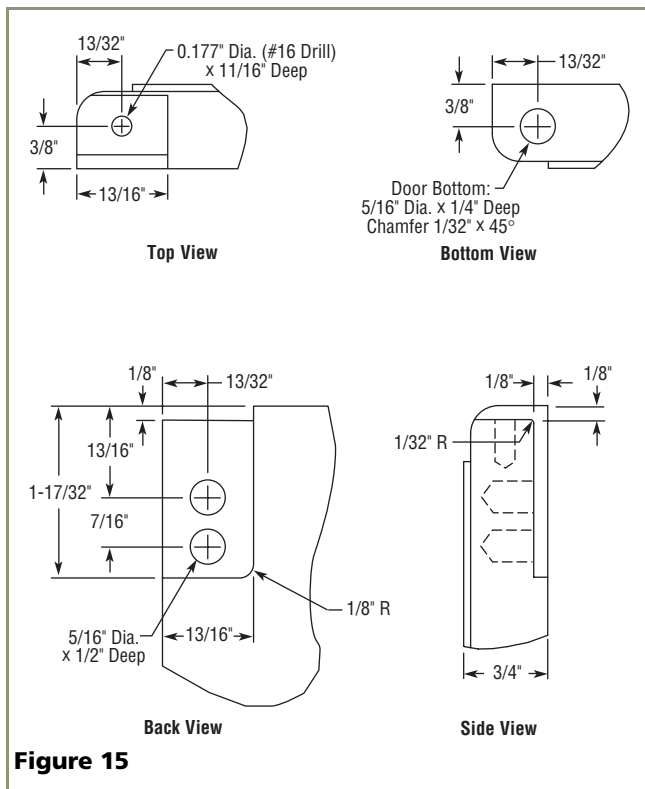

Route notch in top corner of overlay frame as shown (see Top and Side Views). Top of notch is entire depth of frame, front to back.

Width: 13/16"

Depth: 1/8"

Route notch in backside of top corner of overlay frame (see Back and Side Views).

Width: 13/16"

Depth: 1/8"

Height: 1-17/32" from top edge of frame (less 1/8" for depth of notch on top of frame)

Radius of corner notch: 1/8" (see Back View)

4. Drill holes for pivot plate mounts (see **Figure 15**, Back View).

5/16" diameter x 1/2" deep, from the routed surface

CAUTION

Be careful not to drill too deep! Drilling holes too deep may destroy your door frame.

5. Drill hole for upper door hinge (top of frame) (see **Figure 15**, Top View).

0.177" diameter
(#16 drill) x 11/16" deep

6. Drill hole for lower door hinge (see **Figure 15**, Bottom View).

5/16" diameter x 1/4" deep

CAUTION

It is important to ensure that all drilled holes are drilled to the correct depth in order to avoid splits in the wood when hardware is installed.

Installation Instructions

Preparing Door

Note: Door is not attached. It is in a separate box inside the unit box and taped to the unit.

1. Lay door on a clean, flat surface with the gasket facing up.
2. Pull gasket completely out of the groove. Start in the middle and pull outward, moving toward the edge (see **Figure 16**). This may take some force.

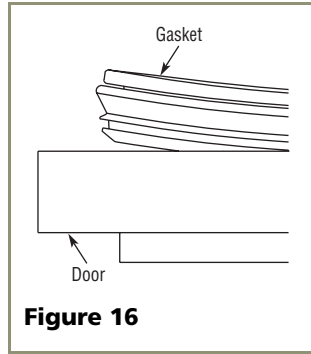

Figure 16

Note: Lay gasket flat on a clean surface to avoid disturbing interior magnet.

Checking Overlay Fit

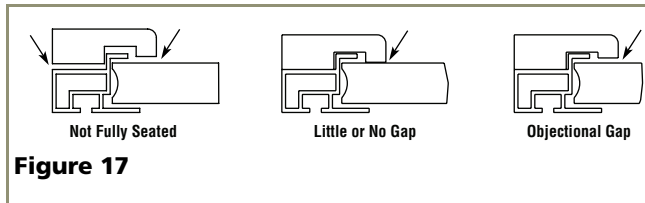

Figure 17

1. Turn door over and lay overlay frame on front side of door. Make sure frame is fully seated on all four sides. See **Figure 17**.
2. Visually check for gap between frame and glass. If there is an objectionable gap, follow steps under *Applying Foam Tape to Overlay Frame*. If there is little or no gap, continue to *Attaching the Overlay Frame*.

Applying Foam Tape to Overlay Frame (If required)

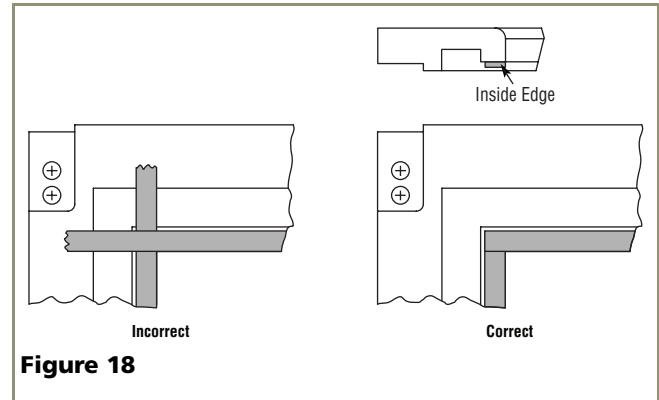

Figure 18

1. Cut foam tape into four pieces, two pieces the width of the overlay frame and two pieces the height of the overlay frame.
2. Remove the adhesive protection strip from one piece of the foam tape and align to the edge of the overlay frame as shown in **Figure 18**, adhering the foam tape to the overlay frame.
3. Trim each piece of tape immediately after application. Do not allow any overlapping of the foam tape. Damage to the overlay frame can occur if the foam tape is not trimmed properly.

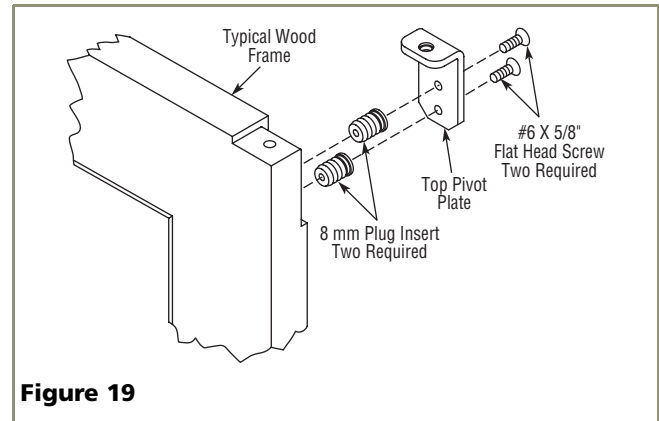

Figure 19

Attaching the Overlay Frame

1. Tap nylon inserts into the top holes drilled in the overlay frame. Use two #6 screws to attach top pivot bracket to the overlay frame (see **Figure 19**).
2. If a user-supplied cabinet handle will be used, attach its hardware to the overlay frame at this time.

IMPORTANT

User-supplied cabinet handle **MUST** be counter bored to make sure mounting hardware is below surface of overlay frame. Failure to do so can cause damage to overlay frame and/or door. Overlay frame will not sit flush to door if mounting hardware is not counter bored.

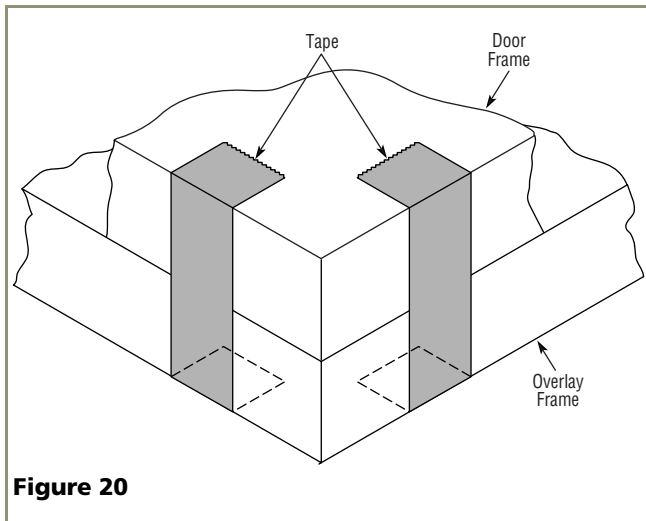

Figure 20

- Secure the front of the door to the back of the overlay frame using tape on all four corners, as shown in **Figure 20**. Make sure all four edges are aligned.

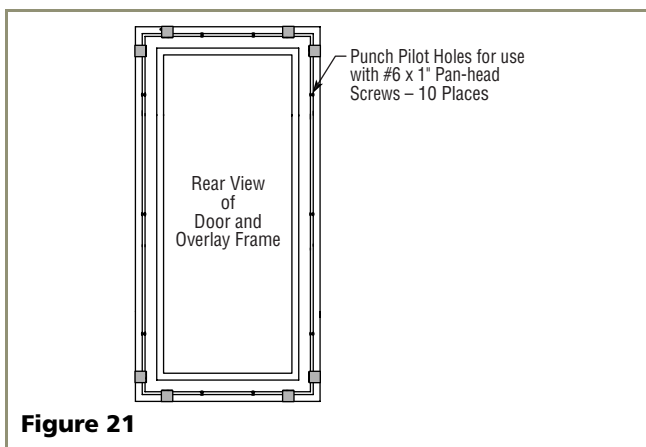

Figure 21

- Place door and overlay frame on a flat, clean protective surface. Use the door frame holes as a guide to lightly punch pilot holes for the #6 x 1" pan-head screws. See **Figure 21**.
- Attach the door to the overlay frame using the #6 x 1" wood screws.

IMPORTANT

If you decide to drill pilot holes, remove the door and do not use a drill bit larger than 7/64". Do not drill deeper than 3/8". Door frame and overlay frame must be aligned properly or the door will not operate correctly.

Note: The door frame is designed with a slight amount of "play" to square it to the overlay frame.

- Remove all traces of tape securing overlay frame to door frame.
- Starting at the corners and working toward the center, push the door gasket back into place. Make sure gasket is seated on all four sides.

Installing the Door

IMPORTANT

Pivot posts must be clean. Closers must also be clean and greased to ensure proper operation.

- Insert pivot post into bottom hinge, making sure to tighten only until post is level with outside of hinge.
- Install door closer. See **Figure 26** on **Page 12**. Be sure that bosses on closers align with holes in hinge.

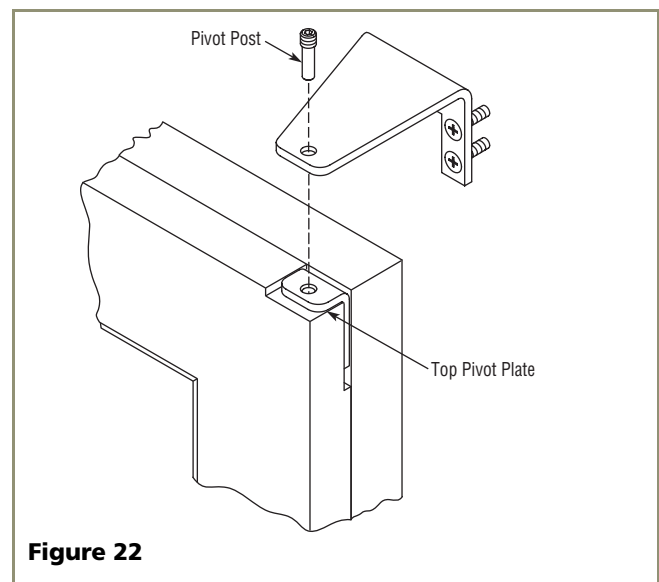

Figure 22

- Holding door upright with top of door tilted forward, place hole of pivot plate onto bottom hinge screw pin. Be sure that bosses on closers align with holes in pivot plate.
- Tilt top of door into position and install top hinge screw pin. See **Figure 22**. Tighten only until post is level with top of hinge.
- Go on to **5 Adjust Door**.

5 Adjust Door

Checking Door Alignment

The unit's door is aligned at the factory before shipment. However, its alignment could have been disturbed during shipment or during overlay frame installation.

IMPORTANT

Properly aligned, the door should be 1/8" below the top of the unit's cabinet, NOT flush with the top (see **Figure 23**).

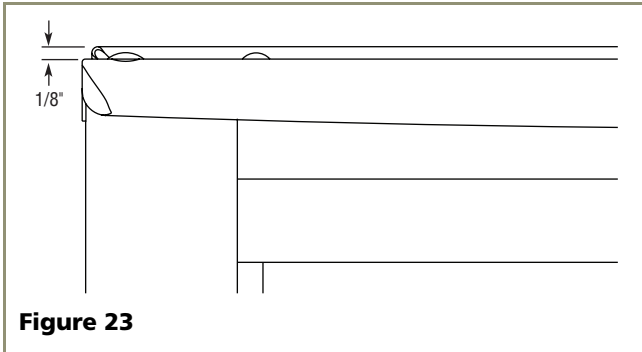

Figure 23

1. Compare the top edge of the door to the top edge of the cabinet.
2. If the door edge is 1/8" below and parallel to the top of the cabinet, go on to **6 Prepare Power Supply**. If it is not, note whether the side opposite the hinge needs to be moved UP or DOWN, and use the following procedure.

Adjusting Door Alignment

1. Remove top hinge screw pin (7/64" Allen wrench or Phillips screwdriver, depending on your unit's construction, see **Figure 24**). Remove door by tilting forward and lifting off bottom hinge pin.
2. With door upside-down, loosen but do not remove the two screws on the door's bottom hinge plate.

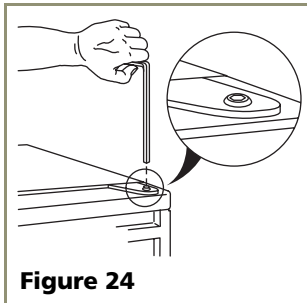

Figure 24

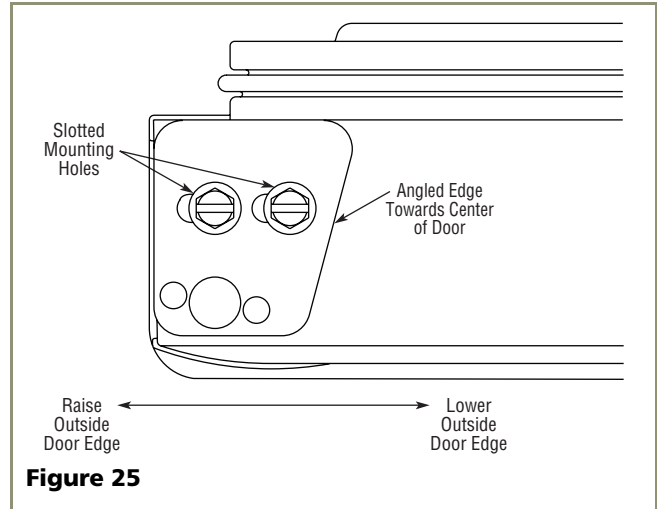

Figure 25

3. See **Figure 25**. If the top far edge of the door needs to move UP, move the hinge plate toward the outside of the door and retighten screws. If the top far edge of the door needs to move DOWN, move the hinge plate toward the inside of the door and retighten screws.
4. Mount the door to recheck alignment and repeat Steps 2 and 3 if further adjustment is necessary.
5. When top edge of door is parallel to top edge of cabinet, remove the door and ensure the two screws are secure.
6. Remove the door closers from the bottom hinge, clean thoroughly and lubricate the mating surfaces with petroleum jelly.
7. Reinstall the closers, lining up the bosses with holes in hinge and hinge plate (see **Figure 26**).
8. Mount the door, install top hinge pivot pin and go on to **6 Prepare Power Supply**.

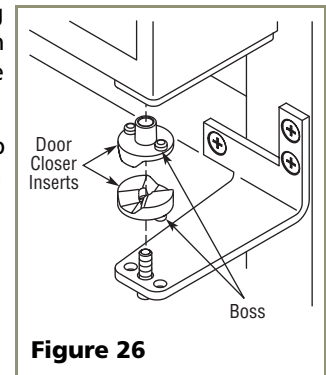

Figure 26

6 Prepare Power Supply

Electrical Specifications

⚠ CAUTION

Electrical installation must observe all state and local codes. This unit requires connection to a grounded (three-prong), polarized receptacle that has been placed by a qualified electrician.

The unit requires a grounded and polarized 115 VAC, 60 Hz, 15A power supply (normal household current). An individual, properly grounded branch circuit or circuit breaker is recommended. GFCI (ground fault circuit interrupter) is usually not required for fixed location appliances and is not recommended for your unit because a GFCI could be prone to nuisance tripping. However, be sure to consult your local codes.

See **Figure 27** for recommended receptacle location.

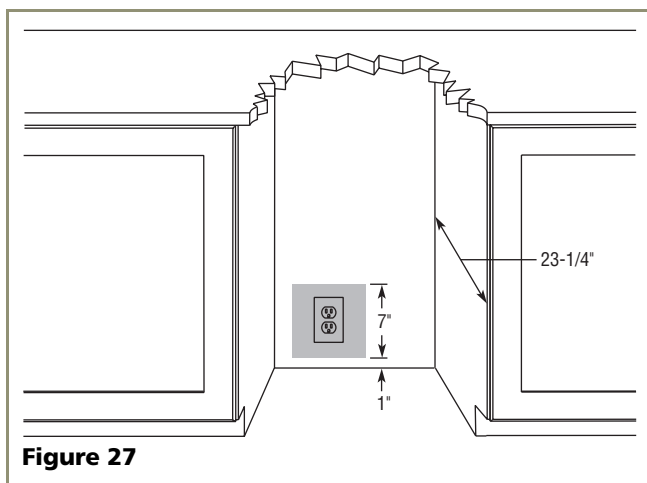

Figure 27

⚠ WARNING

SHOCK HAZARD — Electrical Grounding Required.

- **Never remove the round grounding prong from the plug and never use a two-prong grounding adapter.**
- **Never use an extension cord to connect power to the unit.**

Go on to **7 Level the Unit**.

7 Level the Unit

Leveling Information

Note: It is recommended that the unit is level.

1. Use a level to check the levelness of the Wine Captain® from front to back and from side to side. Level should be placed along top edge and side edge as shown (see **Figure 28**).

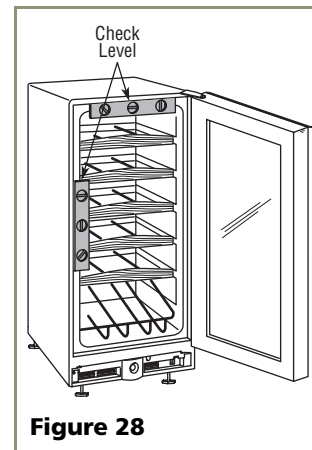

Figure 28

2. If the Wine Captain® is not level, adjust the feet on the corners of the unit as necessary (see **Figure 29**).

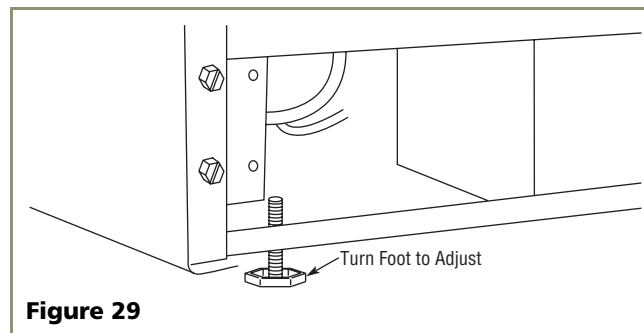

Figure 29

3. Check the levelness after each adjustment and repeat the previous steps until the unit is level. Go on to **8 Install the Unit**.

Installation Tip

If the room floor is higher than the floor in the cut-out opening, adjust the rear feet to achieve a total unit rear height of 1/8" less than the opening's rear height. Shorten the unit height in the front by adjusting the front feet. This allows the unit to be gently tipped into the opening. Readjust the front feet to level the unit after it is correctly positioned in the opening.

8 Install the Unit

Anti-Tip Bracket Installation

1. Locate two Anti-Tip Brackets included inside the unit.
2. Place the unit into the area where it will be installed. Check the door, sides and top for a proper fit. Also test to make sure the door opens and closes freely.
3. Remove grill and place a mark on the floor at the front of the unit. Also place a mark on the floor in the center of the unit. See **Figure 30**.

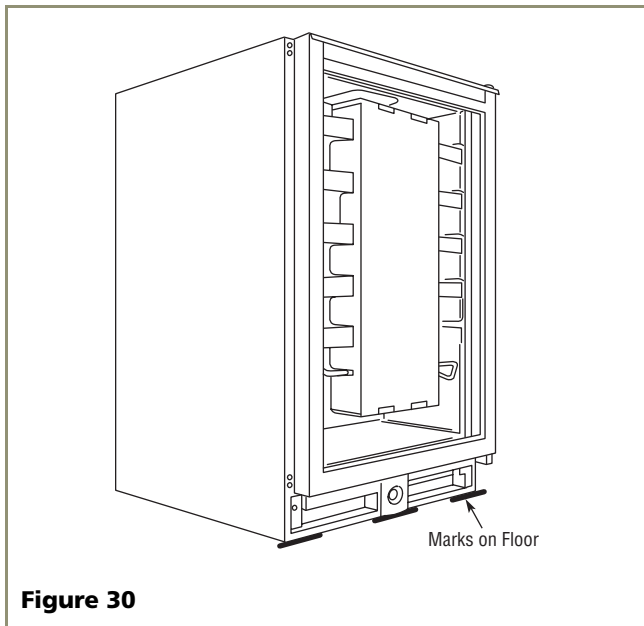

Figure 30

4. Remove the unit. Using a square, extend a centerline 20-1/4" toward the back wall. See **Figure 31**. At the back of the centerline, mark a line that measures 6-9/16" to the left and right. This line serves as the back edge for the Anti-Tip Brackets and its furthest points mark the outer edge of each bracket.

Note: Instructions are shown for built-in installation. Use same dimensions for free-standing installation.

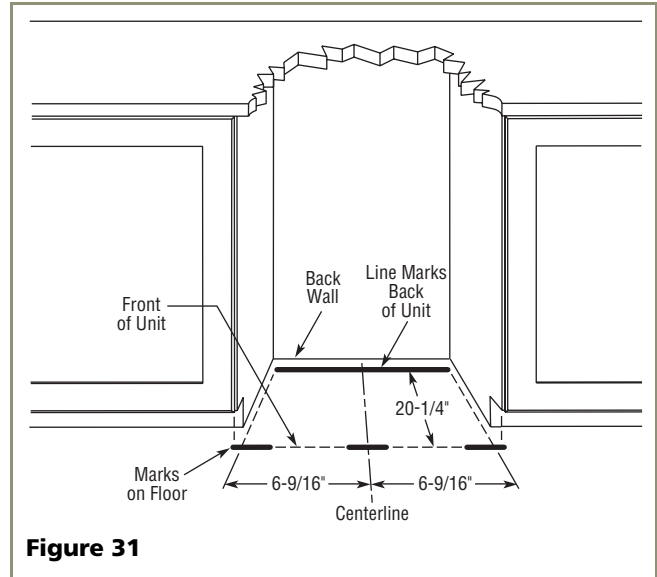

Figure 31

5. Place the Anti-Tip Brackets on the floor against the line drawn for the outer edge. Mark spots for the screw holes. See **Figure 32**.

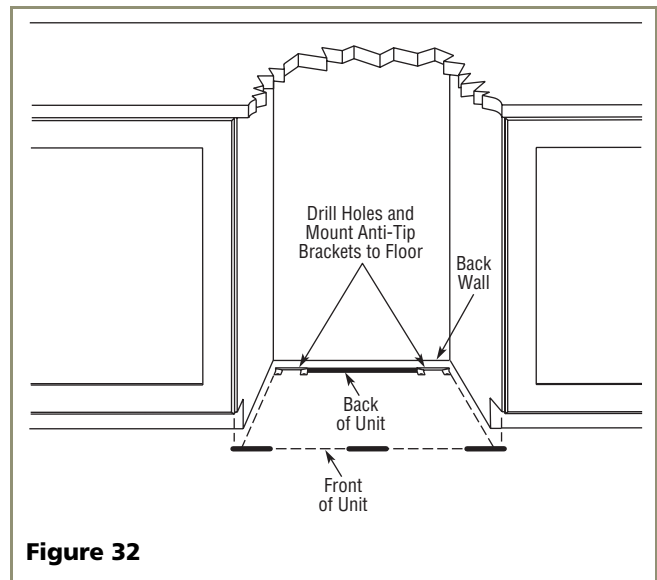

Figure 32

6. Use a 1/8" drill to make two starter holes and fasten the Anti-Tip Brackets to the floor using the screws provided.

CAUTION

Other hardware is required for floors made of materials other than wood.

7. Place the unit back into position, making sure the feet engage the Anti-Tip Brackets properly. Check the alignment of the lines made on the floor in Step 3 with the position of the front feet to ensure proper positioning.

Installation Troubleshooting

Q: Problem

The door remains open unless it is pushed closed.

A: Solution

The hinges should be self-closing when the door is open approximately 8". If this is not the case, make sure the closers (at the bottom of the hinge pin) are clean, greased and installed correctly. Also, re-check leveling from front to back of the unit and readjust if necessary. Make sure that pivot plate is installed correctly.

9 Start-Up for the First Time

Initial Start-Up

The unit is shipped with the control preset. No adjustments should be necessary at this time. For information about Adjusting the Temperature Control, see the User Manual.

Start-Up Troubleshooting

Q: Problem

Unit does not appear to turn on when plugged in.

A: Solution

Make sure outlet has power (circuit breaker has not tripped). Check to see that control is turned on.

Q: Problem

Light is on with door closed.

A: Solution

Make sure switch located to the right of the control dial on the grille is set to OFF.

The Wine Captain® has an interior light that is illuminated when the door is opened. The light can be activated while the door is closed by depressing the switch to the ON position.

IMPORTANT

See the User Manual's *Troubleshooting Guide* for more solutions.

Échelon™ Series

Who to Call

Service Information

If the need for service arises, contact the dealer from whom the unit was purchased. State the Model Number and Serial Number and explain the problem. The Model and Serial Number plate is located inside unit at upper right hand corner.

If you need to locate a service company, you can go online at **www.U-LineService.com** and search for a service company by zip code.

For more than four decades, U-Line has distinguished itself as the leader in built-in undercounter ice making, refrigeration and wine storage appliances.

Échelon™ SERIES / *O r i g i n s* SERIES

U-Line Corporation, located in Milwaukee, WI, is a family operated manufacturer of built-in undercounter icemakers, Combo® icemaker/refrigerators, Wine Captain® wine storage units, refrigerators, refrigerated drawers and refrigerator/freezers.