

Steam Oven

BS 220/221

BS 224/225

Table of Contents

Safety Notes	4	Child Lock	29
Before Use	4	Activating the Child Lock	29
Intended Use	4	Deactivating the Child Lock	29
Safety while Steaming	4	Note	29
Damage to the Appliance	4		
Operating for the First Time	5	Safety Deactivation	30
Avoiding Damage to the Appliance and the Cabinet	5	Changing the Basic Settings	31
Steam Oven and Cabinet Fronts	5	Note	31
Avoiding Damage to the Oven Interior	5	Example: Changing the Standby Screen	31
Features of your New Steam Oven	6	Basic Settings	32
Steam Oven	6	Care and Manual Cleaning	33
Display and Controls	7	Safety Notes	33
Keys	7	Oven Interior	33
		Cooking Inserts	33
Accessories	8	Racks	33
Heating Modes	9	Water Tank	33
		Glass Front	33
Water Tank	10	Door Seal	33
First Settings after Installation	11	Cleaning Function	34
Note	11	How to Proceed	34
Setting the Clock	11	Note	34
Choosing the Time Format	11	Descaling Program	36
Temperature Unit °C or °F	11	How to Proceed	36
Setting the Water Hardness	12	Tip	37
Exiting Menu and Saving Settings	12	Trouble Shooting	38
Calibration	13	Error Messages	38
Calibrating the Steam Oven	13	Power Cut	39
Note	13	Exhibition Mode	39
Activating the Steam Oven	14		
Standby	14		
Activating the Steam Oven	14		
Setting the Steam Oven	15		
Setting the Temperature and Heating Mode	15		
Note	16		
Current Oven Temperature Display	16		
After Every Use	16		
Cooking Table	17		
Timer	25		
Calling up the Timer Menu	25		
Timer	25		
Stopwatch	26		
Cooking Time Duration	27		
Cooking Time End	28		



Safety Notes

Before Use

The appliance is only guaranteed safe to use if installed by a specialist in accordance with the installation instructions. The installer is liable for any damage resulting from incorrect installation.

The appliance may only be connected by a licensed specialist. The local electricity supplier's regulations and construction regulations apply.

Read the instruction manual carefully before operating the appliance. Only then will you be able to operate your appliance safely and correctly. Keep the instruction and installation manual for future reference.

Do not connect the appliance if it has been damaged.

Intended Use

This appliance is intended only for domestic use. Only use the appliance to prepare meals. Do not use the appliance to heat up the room in which it is installed.

Never allow children to play with the appliance.

Do not let adults or children operate the appliance unsupervised:

- if they are mentally or physically unable to use the appliance safely and correctly
- if they don't have the knowledge and experience to use the appliance safely and correctly.

Safety while Steaming

Warning, risk of burns! Do not touch hot interior surfaces of oven. Keep children away.

Warning, risk of fire! Do not store flammable products in the oven. Only leave the parts needed inside the oven during use.

Warning, if preparing food with alcoholic beverages (for example rum, cognac, wine, etc.). Remember that alcohol evaporates at high temperatures. It is possible that vapours released by the alcohol can catch fire.

Warning! Hot steam can escape during use. Do not touch the ventilation openings.

Warning! Hot steam can escape when opening the oven door. Hot water may drip from the door. Keep children away.

Warning! Use an oven glove to take the cooking inserts out of the hot oven. Hot liquid may spill over when taking out the cooking inserts.

Warning, risk of burns! The inside of the door gets very hot during operation; observe appropriate caution when opening the appliance. The open door can swing back.

Do not trap connecting cables of electrical appliances in the hot oven door. The cable insulation can melt. Risk of short-circuiting!

Damage to the Appliance

If the appliance is damaged, switch off the corresponding household fuse. Call after-sales service.

Incorrect repairs are dangerous. Repairs must be carried out by one of our experienced after-sales engineers.

Operating for the First Time

Remove the packaging from the appliance and dispose of it according to local regulations. Be careful to remove all accessories from the packaging. Keep packaging elements and plastic bags away from children.

Check the appliance for transport damage after unpacking it. Do not connect the appliance if it has been damaged.

The appliance must be connected by an authorised specialist. No warranty claims can be lodged for any damage resulting from incorrect connection. Observe the installation instructions.

Thoroughly clean the appliance before using it for the first time. This will eliminate any 'newness' smells and soiling.



This appliance is labelled in accordance with the European Directive 2002/96/EG concerning used electrical and electronic appliances (waste electrical and electronic equipment – WEEE). The guideline determines the framework for the return and recycling of used appliances as applicable.

Avoiding Damage to the Appliance and the Cabinet

Steam Oven and Cabinet Fronts

Do not cover the ventilation openings of the steam oven.

Do not take off the door seal. A damaged door seal must be changed immediately.

After taking the food out of the oven, allow the oven to cool down with the door closed. Do not leave the oven door half open, the hot air can cause damage to adjacent cabinets. The cooling fan will continue to run for a while and will then switch off automatically.

Avoiding Damage to the Oven Interior

The interior of your new steam oven is made out of high grade stainless steel. However, lack of care and maintenance might cause corrosion.

Observe the following tips to avoid corrosion in the oven. No warranty claims can be lodged for any

damage resulting from non compliance with these notes.

- Clean and dry the oven interior after it has cooled down.
- Aggressive cleaners may cause corrosion. Only use hot soapy water to clean the oven interior. Use the cleaning aid.
- Do not use oven cleaner or caustic cleaners. Do not use cleaners containing chloride.
- For regular care of the stainless steel interior we recommend the Gaggenau oven care product. Please observe the notes in the cleaning chapter.
- Salt in the oven reacts aggressively. Salt residues on the oven interior may cause spots of corrosion. Always remove residues immediately.
- Spicy sauces (e.g. ketchup, mustard) and salted food (e.g. salted roasts) contain chloride and acids. These act aggressively on stainless steel. Always clean the oven interior after use.
- If your tap water contains a high chloride content (>40 mg/l) we recommend you use non-carbonated bottled water with a low chloride content instead. Refer to your local water supply company for information concerning your tap water.
- Only use original accessories in the oven interior. Rusting materials (e.g. serving plates, cutlery) may cause corrosion of the oven interior.
- Only use original small parts (e.g. knurled nuts). Order small parts from our after-sales service, should you lose any.

Features of your New Steam Oven

Steam Oven

This manual applies to different models.

The pictures of this manual show the model BS 224/225.

The operation is identical for all models.

The water tank is on the opposite side to the door hinge.

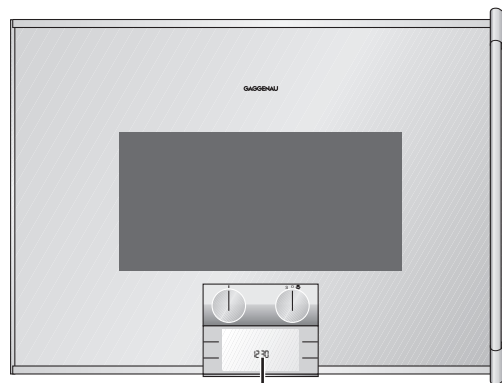

Display and controls

The models BS 220/221 feature display and controls on the bottom front.

These models are especially suitable for installation above an oven.

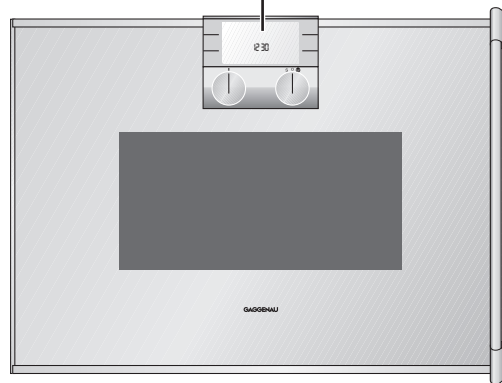

The models BS 224/225 feature display and controls on the top front.

These models are especially suitable for single installation.

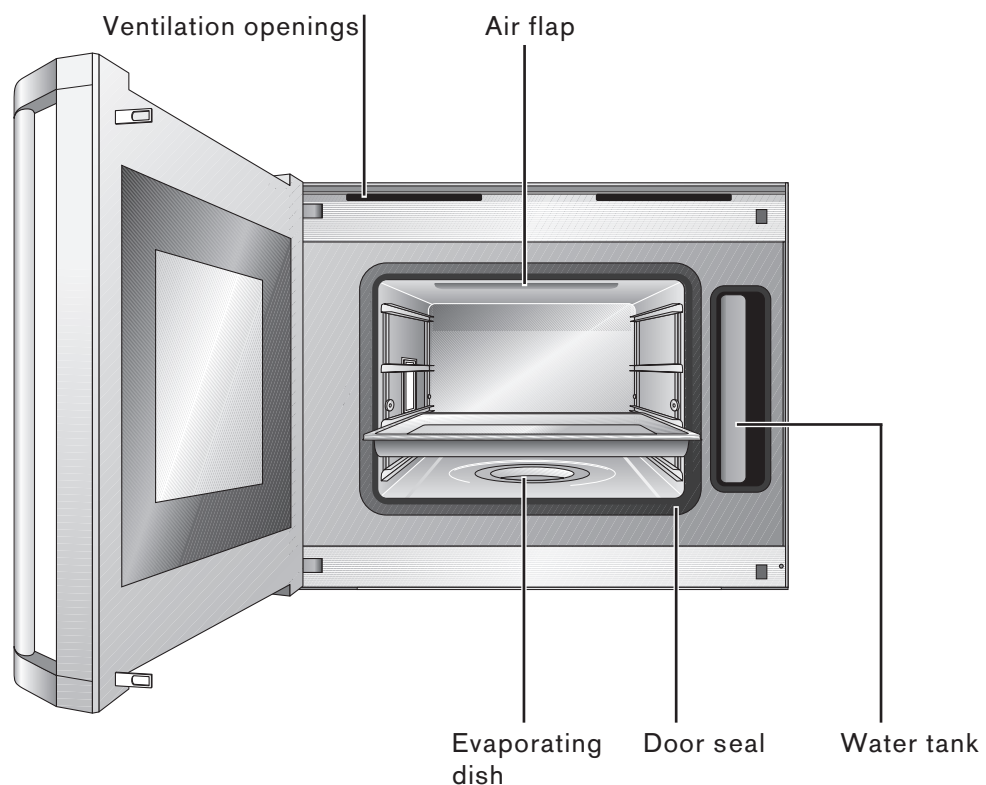

Display and Controls

Display

In the top part of the display is the status bar or a call up menu. The lower part shows the different settings.

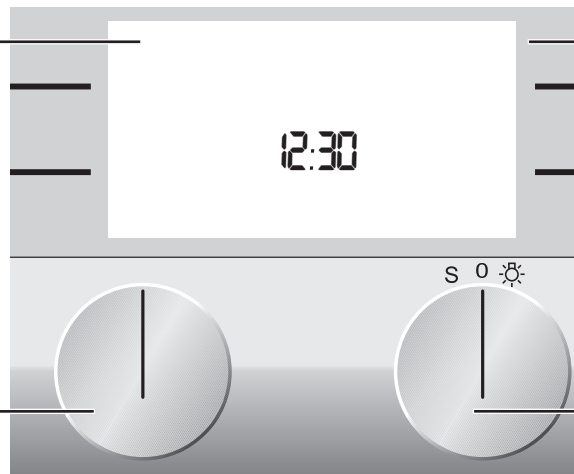

Function selector

Use the left knob to select the cooking mode you will use to prepare your meal. You can turn the knob to the right or left.

Touch keys

The keys on the left and right beside the display are touch sensitive. The function of the keys depends on the chosen setting. The icon beside the key shows the function of the key.

Temperature selector

You can turn the temperature selector to the right or left.

Temperature range is between 30 and 100 °C.

First position to the right: switches on light

First position to the left: operates special functions (cleaning aid, descaling)

Keys

Symbol	Function
>	move right
<	move left
↻	save selected values / start
C	cancel
+	increase values
-	decrease values
🕒	timer menu
🔧	basic settings menu
i	call up current oven temperature
🔒	child lock activate
🔓	child lock deactivate
⏸	timer stop
▶	timer start

Accessories

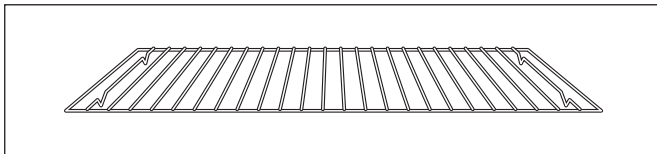
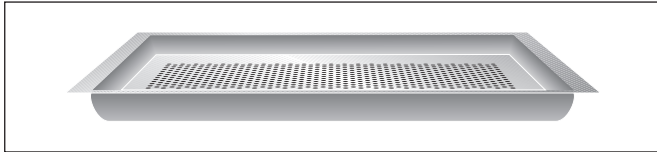
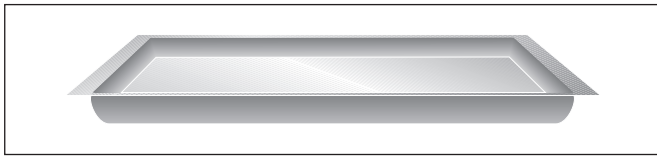





As standard, your appliance comes with the following accessories:

- Stainless steel cooking insert GN 2/3, 40 mm deep
- Stainless steel cooking insert GN 2/3, perforated, 40 mm deep
- Wire rack

You can order the following special accessories:

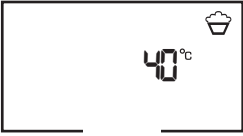
- **KB 220-000:** Stainless steel cooking insert GN 2/3, 40 mm deep
- **KB 220-324:** Stainless steel cooking insert GN 2/3, perforated, 40 mm deep
- **KB 220-114:** Stainless steel cooking insert GN 1/3, 40 mm deep
- **KB 220-124:** Stainless steel cooking insert GN 1/3, perforated, 40 mm deep
- **GR 220-046:** Wire rack

Heating Modes

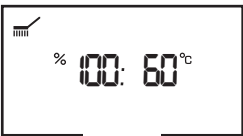
Display	Heating mode	Use
	Steaming temperature 30 - 100 °C	Suitable for fish, vegetables and side dishes, extracting fruit juices and blanching. The dishes are completely surrounded by steam.
	Dough proofing temperature 30 - 50 °C	Raising yeast dough, the perfect temperature setting is 38 °C. The moisture distributes the heat evenly and avoids the surface of the dough drying out.
	Defrosting temperature 40 - 60 °C	Even and gentle defrosting of vegetables, meat, fish and fruit. The food will not dry out and will keep its shape.
	Regenerating temperature 60 - 100 °C	Gently refresh previously prepared dishes. The moisture keeps the food from drying out.
	Low-temperature steaming temperature 70 - 90 °C	Gentle cooking of meat or poultry.
	Cleaning aid, descaling	The cleaning aid loosens soiling with steam.

Water tank

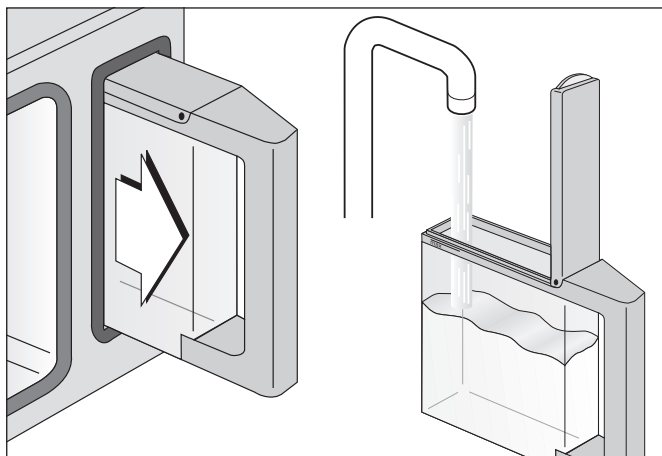

When you open the door of the oven, you will find the water tank on the side. Depending on the model, the tank is on the right or left side.

Before use, fill the water tank to the MAX marking with fresh, cold water.

If the water in your area is very hard, it is better to use filtered water or non-carbonated bottled water. Do not use distilled water or other liquids.

Firmly close the lid of the tank. This is important for the correct functioning of the oven.

Fully insert the water tank until it engages.

If the water tank is empty, the heating stops. The  symbol appears on the display and three dashes instead of the temperature are shown.

Open the oven door (Caution: steam might escape). Slowly pull out the water tank from the slot. A small amount of water might drip from the valve. Hold the water tank level when you pull it out.

Fill the water tank to the MAX marking and re-insert it.

Empty the water tank after every use and leave it to dry with the lid open. Keep the seal in the lid clean and dry after every use. Dry the slot for the tank after every use.

Note:

Do not heat up the water tank in the oven to dry it! This will damage the water tank.

First Settings after Installation

When your new steam oven has been connected, the first settings menu appears on the display. You can set the

- clock,
- time format,
- temperature unit,
- water hardness.

Note

The first settings menu appears only after the appliance has been connected or if the appliance is without electricity for several days.

Refer to the chapter basic settings if you wish to change these parameters at any time.

Setting the Clock

The clock function appears on the screen.

Using the **+** / **-** keys set the correct time.

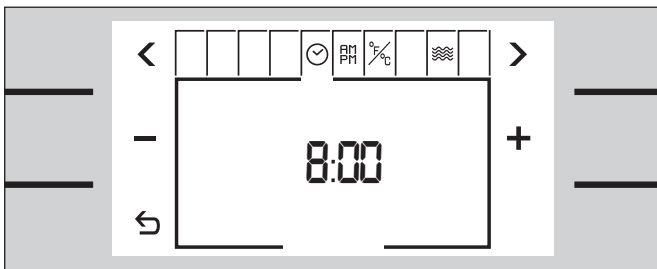

Choosing the Time Format

- 1 Using the menu key **>** select the time format setup menu.
- 2 The time format can be either 12 hour format (AM/PM) or 24 hour format. The 24 hour format is pre-selected.

You can change the time format using the **+** / **-** keys.

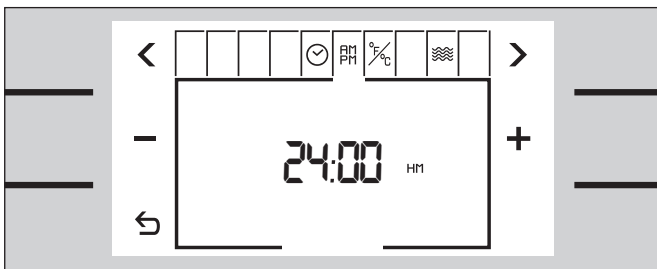

Temperature Unit °C or °F

- 1 Using the menu key **>** select the temperature unit function **%C**. °C is pre-selected.
- 2 You can change the temperature unit using the **+** / **-** keys.

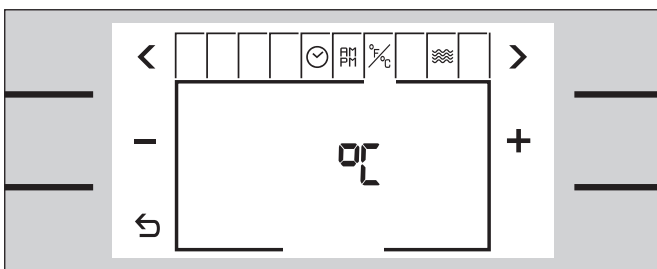

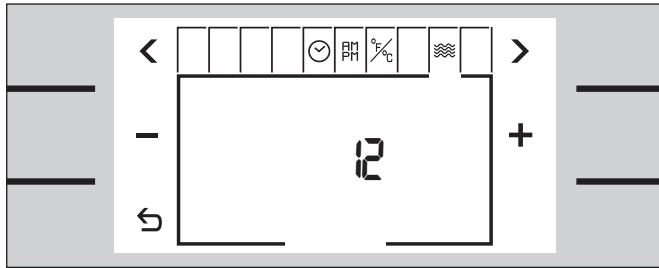

Setting the Water Hardness

- 1 Use the test kit included to test the water hardness of your tap water. Fill the phial with mains water up to the 5 ml marker.
- 2 Add indicator solution drop by drop until the colour changes from purple to yellow.
Carbonate hardness content:
1 drop = 1°KH = 1.25°e = 1.8°f
Please note: count the number of drops that are necessary and gently shake the phial after each drop.
- 3 Use the **+** / **-** keys to enter the value between 1 and 18. Pre-set value is 12. Depending on the value entered the appliance will calculate the intervals for descaling.

Exiting Menu and Saving Settings

Touch the ↩ key to exit the menu. All settings are saved.

The appliance is on standby. The standby screen appears.

Calibration

The boiling point depends on the air pressure. The higher the altitude, the lower the air pressure, and also the boiling point.

During the first steaming after installation, the appliance calibrates the boiling point. During calibration, the appliance is adjusted to the pressure of the altitude where the appliance is installed.

Calibrating the Steam Oven

- 1 Remove all accessories from the oven (cooking inserts, wire rack). The oven must be empty and cold.
- 2 Fill the water tank to the MAX marking with cold water. Firmly close the lid. Fully insert the water tank until it engages.
- 3 Turn the temperature knob to 100 °C and the function knob to steaming.

The steam oven starts to calibrate. During calibration more steam might escape from the oven than during normal use. Calibration takes about 15 minutes.

Note

If the oven has not yet been calibrated, **CAL** is shown beside the current oven temperature when you press the **i** info key.

Do not interrupt the calibration cycle. Do not open the oven door during calibration.

Should the calibration process be interrupted by opening the door or switching off the appliance, the steam oven will not function. Switching on the appliance will automatically restart calibration until the operation has been completed. The steam oven will not function until it has been calibrated.

Recalibration is not necessary after a power failure.

Recalibrate the appliance manually if you should move home to a different altitude.

- Disconnect the appliance from the electricity for a few seconds (switch off the household fuse or the circuit breaker in the fuse box).
- Within 3 minutes after reconnecting the appliance, go to the basic settings menu and activate exhibition mode, then deactivate exhibition mode again.
- Now it is possible to recalibrate the appliance.

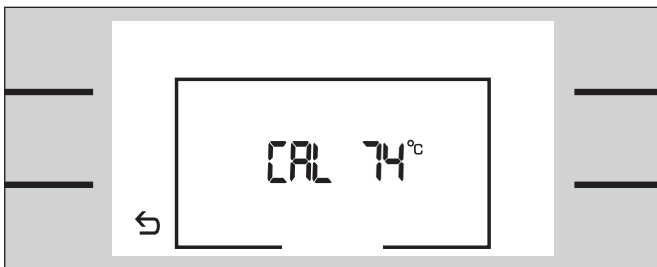

Activating the Steam Oven

Standby

The steam oven remains on standby when no operating mode is selected or the child lock is activated.

The keys are not activated. The display is not lit.

Note:

You can choose between different standby screens. Refer to the chapter basic settings if you want to change the standby screen.

Note:

The display contrast depends on the vertical viewing angle.



Activating the Steam Oven

To leave standby do one of the following:

- touch a key
- open or close the oven door
- turn the temperature knob
- turn the function knob

Now you are able to set the required function. Read the relevant chapter on how to activate the required function.

Note:

The standby screen reappears after one minute if no further function is chosen. The display light goes off.

Setting the Steam Oven

The main operations of your steam oven are easily set using the knobs.

Using the right knob you can set the temperature. To switch on the light in the oven, turn the temperature knob one position to the right.

Temperature range:

Steaming	30 - 100 °C
Dough proofing	30 - 50 °C
Defrosting	40 - 60 °C
Regenerating	60 - 100 °C
Low temperature steaming	70 - 90 °C

The light in the oven remains off if the temperature is set below 70 °C.

Using the left knob you can set the heating mode. The top position is steaming.

Setting the Temperature and Heating Mode

- 1 Fill the water tank to the MAX marking with cold water. Firmly close the lid. Fully insert the water tank until it engages.
- 2 Turn the function knob until the required heating mode appears on the screen.
- 3 Set the temperature knob to the required temperature.
Temperature, moisture level and cooking mode symbol appear on the display. The light in the oven goes on.

The heating up symbol  appears until the required temperature is reached. The symbol appears again when the oven heats during operation.

The temperature and heating mode can be changed at any time.

When the meal is ready switch the steam oven off using the temperature knob. The oven light goes off. The standby screen appears.

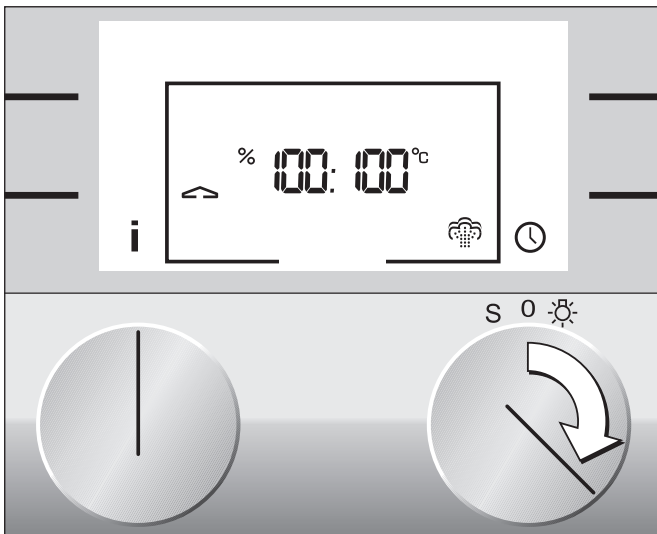

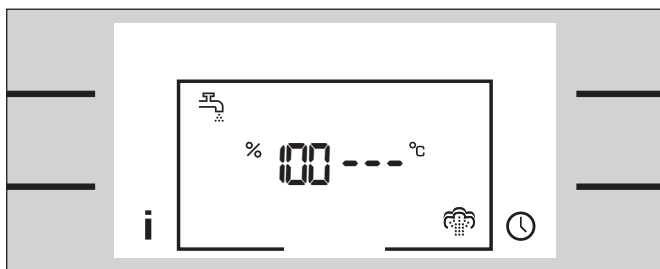



Note

If the  symbol appears on the left top side of the display and three dashes instead of the temperature, the water tank is empty. Fill the water tank to the MAX marking with fresh water.

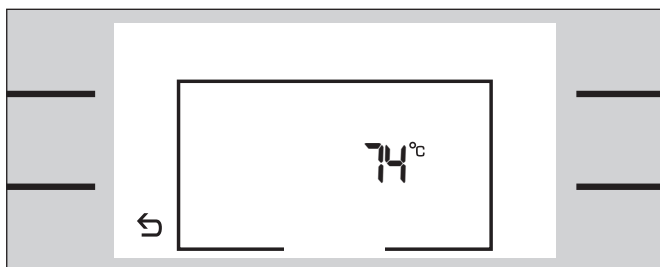
If three dashes appear on the display instead of the temperature, the knobs have not been set to the correct position. Check the position of the temperature and function selectors.



Current Oven Temperature Display

The current oven temperature is briefly shown when you press the **i** info key. Using the  key you can return to the standard screen.

Note:

Depending on the heating mode, a slight temperature variation after heating up during use is normal.

After Every Use

Wipe the oven interior and the evaporating dish with a soft sponge. Dry the oven interior with a cloth.

⚠ Warning! The water in the evaporating dish can be hot.

Empty the water tank and leave it to dry with the lid opened. Dry the slot in the appliance.

Cooking Table

Important Notes

- The cooking times given are only a recommendation. The effective cooking time depends on the quality of the food, its temperature, the amount and the size of the food.
- Always preheat the oven. This will guarantee the best results.
- The cooking times given here are for a preheated oven. Add about 5 minutes to the cooking time if the oven has not been preheated.
- The values given are for 4 average portions. Add to the cooking time for larger amounts.
- Use the recommended cooking inserts. Using different cooking inserts might change the cooking times.
- Try new dishes at the shortest time value given. If necessary, extend the cooking time.
- Only open the oven door for a short time when putting food in the oven.
- If you use only one level, place the cooking insert on the second level from the bottom.
- When using the perforated cooking insert, place the unperforated cooking insert on the first level from below to avoid the bottom of the oven interior and the evaporating dish becoming soiled.
- You can use simultaneously up to three levels (level 2, 3 and 4 from the bottom). You can cook different dishes simultaneously without flavour transfer. However, the cooking times may increase for large amounts of food.
- Food being cooked must not come into contact with the oven compartment.
- The steam oven door must seal well. Always keep the door seal clean.
- Do not place too much food on the wire rack or the cooking insert. This will ensure optimum circulation of the air.

Vegetables

- The cooking times are for 1 kg of cleaned vegetables.
- Use the perforated cooking insert on the second level from below. Place the unperforated cooking insert on the first level from below to avoid the oven interior becoming soiled. Use the vegetable stock that collects in the unperforated cooking insert as a base for sauce or stock.

Dish	Cooking insert	Temperature in °C	Moisture in %	Cooking time in minutes
Artichoke, large	perforated	100	100	25-35
Artichoke, small	perforated	100	100	15-20
Cauliflower, whole	perforated	100	100	20-25
Cauliflower, in roses	perforated	100	100	15-20
Green beans	perforated	100	100	25-30
Broccoli, in roses	perforated	100	100	10-15
Fennel, sliced	perforated	100	100	10-15
Vegetable tureen	tureen / wire rack	100	100	50-60
Carrots, sliced	perforated	100	100	10-15

Dish	Cooking insert	Temperature in °C	Moisture in %	Cooking time in minutes
Potatoes, peeled and quartered	perforated	100	100	20-35
Kohlrabi, sliced	perforated	100	100	15-25
Leeks, sliced	perforated	100	100	5-10
Jacket potatoes (ca. 50 g each)	perforated	100	100	25-30
Jacket potatoes (ca. 100 g each)	perforated	100	100	40-45
Brussel sprouts	perforated	100	100	15-20
Asparagus, green	perforated	100	100	10-15
Asparagus, purple	perforated	100	100	18-25
To skin tomatoes*	perforated	100	100	3-4
Sugar peas	perforated	100	100	10-15

*To skin tomatoes: cut peel once, place in ice water after steaming.

Fish

- Steaming is a gentle cooking process and fish retains its taste.
- Salt the fish after steaming. Thus, the natural aroma is preserved and the fish does not dry out.
- When using the perforated cooking insert grease it lightly to prevent the fish sticking to it.
- Fillets with skin: place the fish with the skin to the top, this preserves the texture and aroma.

Dish	Cooking insert	Temperature in °C	Moisture in %	Cooking time in minutes
Bream, whole, 700 g	perforated	90-100	100	20-25
Fish dumplings, 20-40 g each*	unperforated	90-100	100	5-10
Carp, whole, 1.5 kg	perforated	90-100	100	40-50
Salmon fillet, 300 g each	perforated	90-100	100	12-15
Salmon, whole, 2.5 kg	perforated	100	100	70-80
Mussels, 1.5 kg**	perforated	100	100	8-12

*Fish dumplings: cover the unperforated cooking insert with baking paper.

** The mussels are ready when their shells open.

Dish	Cooking insert	Temperature in °C	Moisture in %	Cooking time in minutes
Hake, whole, 800 g	perforated	90-100	100	20-25
Monkfish fillet, 200 g each	perforated	90-100	100	10-15
Bass, whole, 400 g each	perforated	90-100	100	15-20

Fish – Low-temperature Steaming

- Steaming fish between 70 and 90 °C prevents it from becoming soft und breaking apart. This is especially suitable for sensitive fish. Use the “low-temperature steaming” mode.
- The values are for fillets of fish.
- Serve on warmed dishes.

Dish	Cooking insert	Temperature in °C	Cooking time in minutes
Oysters, in stock (10 oysters)	unperforated	80-90	2-5
Tilapia, 150 g each	perforated	80-90	10-12
Bream, 200 g each	perforated	80-90	12-15
Fish tureen	tureen / wire rack	70-80	50-90
Trout, whole, 250 g each	perforated	80-90	12-15
Halibut, 300 g each	perforated	80-90	12-15
Scallops (6 scallops)	unperforated	80-90	4-8
Cod, 250 g each	unperforated	80-90	10-12
Red Snapper, 200 g each	perforated	80-90	12-15
Ocean perch, 120 g each	unperforated	80-90	10-12
Rolled sole, stuffed, 150 g each	perforated	80-90	12-15
Turbot, 300 g each	perforated	80-90	12-15
Bass, 150 g each	perforated	80-90	10-12
Pike-perch, 250 g each	perforated	80-90	12-15

Meat / Poultry – Low-temperature Cooking

- Seared meat matures over a longer time at a low temperature in the oven. The food will remain juicy and preserve most of its nutrients. Use the “low-temperature steaming” mode.
- Take the meat from the fridge one hour before cooking.
- For hygienic reasons, briefly sear the meat from all sides in a hot pan on the hob before putting it in the oven. This will give the roast the typical flavour.
- To prevent the rind from becoming soft, wrap the meat in a roasting bag or heat-resistant plastic wrap after searing before putting it in the preheated oven to mature. Thus, the meat cooks in its own moisture.
- The cooking times given are only a recommendation. The effective cooking time depends on the temperature of the food and the roasting time on the hob. Please note that the core temperature of the food will always stay below the set temperature in the oven.
- As a recommendation, set the oven temperature 10-15°C higher than the required core temperature.
- Serve on warmed dishes.

Dish	Cooking insert	Temperature in °C	Cooking time in minutes
Duck breast, medium, 350 g each	unperforated	70-80	40-60
Entrecôte, medium, 350 g each	unperforated	70-80	20-40
Leg of lamb, without bone, tied, medium, 1.5 kg	unperforated	70-80	150-180
Roast beef, medium, 1-1.5 kg	unperforated	70-80	120-180
Pork medallions, well-done, 70 g each	unperforated	80	30-40
Beef steaks, medium, 200 g each	unperforated	70-80	20-40

Heating up Meat or Sausages

Dish	Cooking insert	Temperature in °C	Moisture in %	Cooking time in minutes
Smoked pork chop, sliced	unperforated	100	100	15-20
Boiled sausages (e.g. Lyoner, white sausage)	unperforated	85-90	100	10-20

Steaming Poultry

Dish	Cooking insert	Temperature in °C	Moisture in %	Cooking time in minutes
Stuffed chicken breast, 200 g each	unperforated	100	100	10-15
Poussins, quails, pigeons, 300 g each	perforated	100	100	25-30
Turkey breast, 300 g each	perforated	100	100	12-15

Side Dishes / Rice

The cooking time is a rough value. Observe the manufacturer's recommendations.

Dish	Cooking insert	Temperature in °C	Moisture in %	Cooking time in minutes
Basmati rice (250 g + 500 ml water)	unperforated	100	100	20-25
Cous-cous (250 g + 250 ml water)	unperforated	100	100	5-10
Dumplings, 90 g each	perforated	95-100	100	25-30
Long grain rice (250 g + 500 ml water)	unperforated	100	100	25-30
Brown rice (250 g + 375 ml water)	unperforated	100	100	25-35
Lentils (250 g + 500 ml water)	unperforated	100	100	25-35
Fresh pasta, cooled	perforated	100	100	5-7
Fresh pasta, with filling, cooled	perforated	100	100	5-10
Pre-soaked white beans (250 g + 1 l water)	unperforated	100	100	55-65

Dessert

Dish	Cooking insert	Temperature in °C	Moisture in %	Cooking time in minutes
Crème Brulée, 130 g each	soufflé dishes / perforated	90-95	100	35-40
Yeast dumplings, 100 g each	unperforated	100	100	20-30
Flan/Crème Caramel*, 130 g each	soufflé dishes / perforated	90-95	100	25-30
Compote	unperforated	100	100	5-15
Milk rice (250 g rice + 625 ml milk)	unperforated	100	100	35-45

*Cover crème caramel or flan with heat-resistant cling film or aluminium foil.

Miscellaneous

Dish	Cooking insert	Temperature in °C	Moisture in %	Cooking time in minutes
To desinfect baby bottles or jam jars	wire rack	100	100	20-25
Eggs, size M (5 eggs)	perforated	100	100	8-15
Cooked-egg-garnish*, 500 g	glass dish / wire rack	90	100	25-30
Semolina dumplings	unperforated	90-95	100	8-10

*Cover cooked-egg-garnish with heat-resistant cling film or aluminium foil.

Regenerating (Reheating)

- Reheat previously prepared dishes without loss of quality. Select the "Regenerating" heating mode.
- The given values are for dishes reheated on a plate. To regenerate larger amounts use the unperforated cooking insert. You will need to increase the time.

Dish	Cooking insert	Temperature in °C	Cooking time in minutes
Vegetables (on a plate)	wire rack	90-100	7-10
Side dishes (pasta, potatoes, rice)*	wire rack	100	10-12

*Side dishes: not suitable are baked or deep fried foods like french fries or potato croquettes.

Dough Proofing

- Raising yeast dough and other dough mixtures without drying out. Do not cover the bowl. Select the "Dough Proofing" heating mode.
- The raising time is a rough value. Leave the dough until it has doubled in size.

Dish	Cooking insert	Temperature in °C	Cooking time in minutes
Dough mixture (for example yeast dough, baking ferment, sour dough mixture)	bowl / wire rack	38	25-45

Defrosting

- Select the “Defrosting” heating mode.
- The defrosting time given is a rough value. The defrosting time depends on the size, weight and shape of the frozen food. Always freeze your food flat or in single pieces, this shortens the defrosting time.
- Take the food out of the packaging before defrosting.
- Only defrost the amount that you will need to prepare.
- Please observe: defrosted food might not keep and will deteriorate more quickly than fresh food. Immediately prepare defrosted food and cook it thoroughly.
- Poultry, fish and meat: Important! Always insert an unperforated cooking insert one level below the food. Pour away the defrosting liquid of meat and poultry. Clean the sink afterwards and rinse with plenty of water. Clean the cooking insert in hot soapy water or in the dishwasher.

Dish	Cooking insert	Temperature in °C	Cooking time in minutes
Berries, 300 g	perforated	40-45	3-4
Roast , 1000 g	perforated	40-45	45-60*
Fish fillet, 150 g each	perforated	40-45	5-10*
Vegetables , 400 g	perforated	40-45	5-7
Goulash , 600 g	perforated	45-50	30-45*
Chicken , 1000 g	perforated	45-50	45-60*
Chicken legs, 400 g each	perforated	45-50	20-30*

*After the time has elapsed, leave the food inside the oven for 10-15 minutes after switching off. This ensures the food is thawed right through.

Preserving

- Cook the fruit or vegetables immediately after buying or picking. A prolonged storage will reduce the vitamins and might lead to fermenting.
- Only use good quality fruit and vegetables.
- Check and clean the preserving jars, rubber seals and clamps.
- Disinfect the clean jars in the oven for 20-25 minutes at 100°C / 100% moisture before using them for preserving.
- Open the oven door after the cooking time has elapsed. Leave the jars to cool down completely before taking them out of the oven.

Dish	Cooking insert	Temperature in °C	Moisture in %	Cooking time in minutes
Fruit, vegetables (in closed preserving jars 0.75l)	perforated	100	100	35-40

Extracting Juice

- Place the fruit or berries in the perforated cooking insert. Insert the perforated cooking insert with the fruit on the second level from below. Place the deep unperforated cooking insert one level lower to collect the juice.
- Leave the fruit in the oven until no more juice comes out.
- You can squeeze the food in a dish towel afterwards to gain the remaining juice.

Dish	Cooking insert	Temperature in °C	Moisture in %	Cooking time in minutes
Berry fruit	perforated	100	100	60-120

Preparing Yogurt

- Heat pasteurised milk on the hob to 90 °C to avoid damaging the yogurt bacteria. You do not need to heat up long-life milk. (Note: the time needed for maturing will be lengthened if you use cold milk to produce the yogurt).
- Important! Cool the milk in a bain-marie until it reaches 40 °C to avoid destroying the yogurt bacteria.
- Stir natural yogurt (use yogurt with yogurt bacteria) into the milk (1-2 teaspoons for every 100 ml).
- In the case of yogurt ferment, pay attention to the notes on the packet.
- Pour the yogurt into clean jars.
- Disinfect the clean yogurt jars in the oven for 20-25 minutes at 100°C / 100% moisture before filling them with yogurt. Note: let the jars and the oven cool down before filling the jars with yogurt to put them in the oven.
- On completion, place the yogurt in the fridge.
- Add skimmed milk powder to the milk before heating it (1-2 tablespoons per litre) to get a more solid yogurt.

Dish	Cooking insert	Temperature in °C	Moisture in %	Cooking time in minutes
Fresh yogurt (in closed jars)	perforated	45	100	240-360

Timer

Using the timer menu you can set the following:

- ⌚ timer
- ⌚ stopwatch
- ⌚ cooking time duration (not during stand-by)
- ⌚ cooking time end (not during stand-by)

Calling up the Timer Menu

Touch the key beside the symbol ⌚ to call up the timer menu.

If the appliance is on standby, touch any key. Now the display is activated. The info **i** and timer ⌚ symbols are shown.

Touch the key next to the timer symbol ⌚. The timer menu appears.



Timer

The timer counts down independently of all other settings of the appliance. You can enter a maximum value of 90 minutes.

Setting the Timer

- 1 Call up the timer menu. The timer function ⌚ is shown on the display.
- 2 Using **+** or **-** set the desired duration.
- 3 Start using the ⏪ key.

The timer menu is closed.

A signal sounds when the time has elapsed. Touch the ⌚ key to switch off the signal.

Note

To cancel an active timer:
Call up the timer menu, select the timer function ⌚ and touch the **C** key.

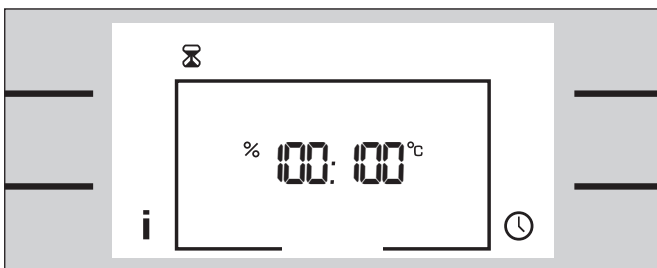
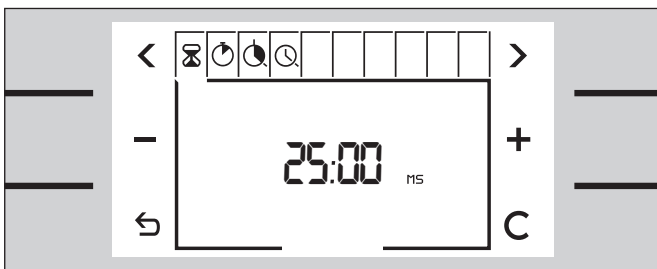

Stopwatch

The stopwatch will count the elapsed time up to 90 minutes.

The pause function pauses the stopwatch.

The stopwatch runs independently of all other settings of the appliance.

Starting the Stopwatch

- 1 Call up the timer menu.
- 2 Using < or > select the stopwatch function ⌚.
- 3 Start using the ▶ key.

The timer menu is closed.

The timer menu is closed immediately when you touch the ↶ key.

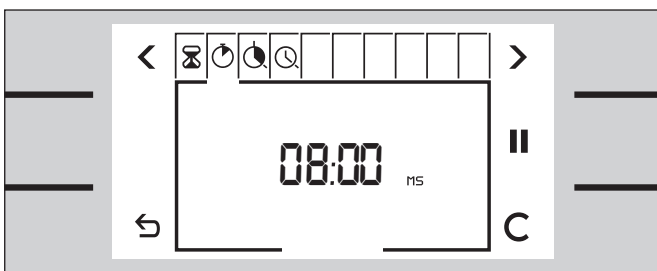
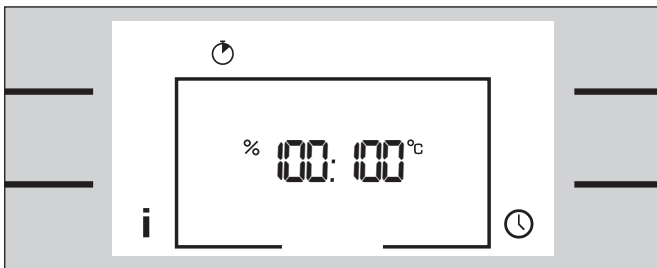
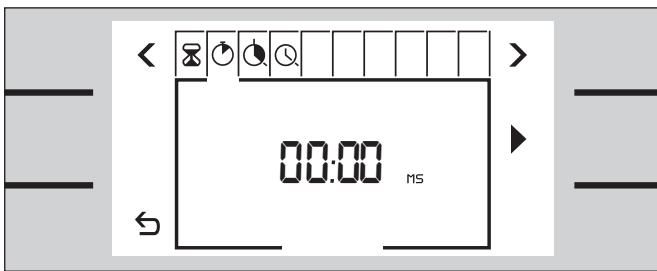

Pausing the Stopwatch

- 1 Call up the timer menu.
- 2 Using < or > select the stopwatch function ⌚.
- 3 Touch the || key. The counter stops. The key reverts to start ▶.
- 4 Start again using the ▶ key. The counter continues.

After 90 minutes the time reverts to 00:00 minutes. The symbol ⌚ in the status bar disappears. The stopwatch is switched off.

Note

To cancel the stopwatch:
Call up the timer menu, select the stopwatch function ⌚ and touch the C key.

Cooking Time Duration

If you set a cooking time duration for your meal, the appliance switches off automatically after the selected time.

This enables you to leave the kitchen while the meal is being prepared.

You can select a cooking time between 1 minute and 23 hours 59 minutes.

Select the temperature and heating mode and place your meal in the oven.

Switching off Automatically

- 1 Call up the timer menu.
- 2 Using **<** or **>** select the cooking time duration function .
- 3 Using **+** or **-** set the required cooking time.
- 4 Start the program using the **↵** key.

The timer menu is closed. Temperature and heating mode are shown on the display.

After the time has elapsed the appliance switches off. A signal sounds. Touch the  key or open the appliance door to switch off the signal.

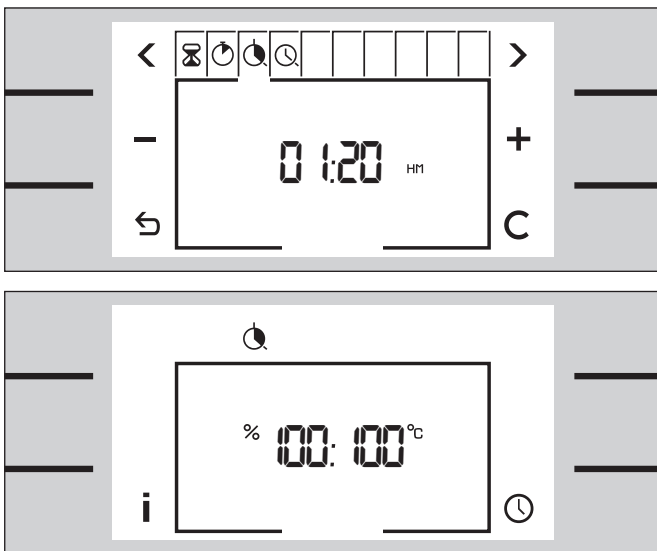

Note

The cooking times given in the cooking table are for a preheated oven. Add about 5 minutes to the cooking time if the oven has not been preheated.

To cancel the cooking time:

Call up the timer menu. Touch the **C** key, then touch **↵** to confirm.

To change the cooking time:

Call up the timer menu. Change the time with **+** or **-**, then touch **↵** to confirm.

To stop the program:

Switch the temperature knob off.

Cooking Time End

You can program a cooking time end. Example: it is 13:30. The meal will take 40 minutes to cook and must be ready at 15:30.

Set the cooking time duration and set the cooking time end to 15:30. The electronics will calculate the start time. The appliance will start automatically at 14:50 and switch off at 15:30.

Please note that food which can easily go off should not stay in the oven too long.

Note:

Always set the desired temperature, heating mode and cooking time duration first. Only by setting these values can the cooking time end be programmed.

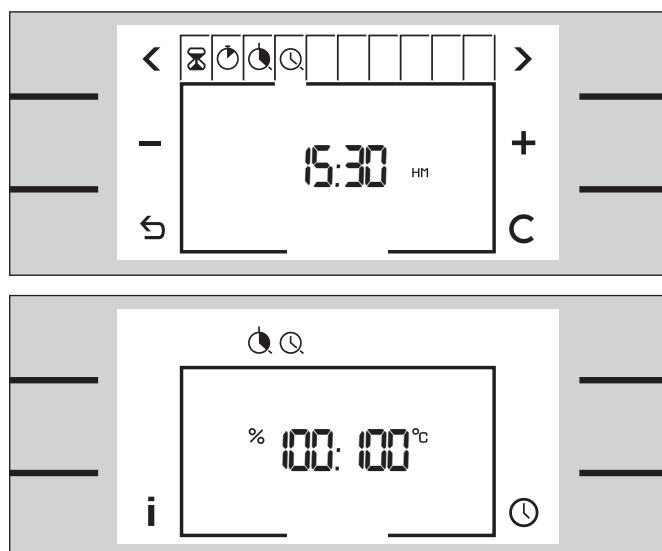

Switching on and off Automatically

- 1 Set the required cooking time.
- 2 Using > select cooking time end ⌚. The switch off time appears on the display.
- 3 Using + set a later switch-off time.
- 4 Start using the ↵ key. The timer menu is closed.

Temperature and operating mode appear on the display. The appliance is on standby and will start automatically. After the cooking time duration it will switch off.

After the time has elapsed the appliance switches off. A signal sounds. Touch the ⌚ key, open the appliance door or switch off the temperature selector to switch off the signal.

Note

To cancel the cooking time:

Call up the timer menu. Touch the C key, then touch ↵ to confirm. Cooking time duration and end are cancelled.

To stop the program:

Switch the temperature knob off.

If the ⌚ symbol flashes:

You have not set the cooking time duration. Always set the cooking time duration first.

Child Lock

The steam oven has a child lock. It prevents the oven being turned on unintentionally.



Supposition:

You have to make the child lock available in the basic settings. See chapter basic settings.

Activating the Child Lock

Supposition:

The temperature knob is in the OFF position.



- 1 Touch any key. The symbol  appears beside the centre left key.
- 2 Touch the key  for at least 6 seconds.

The child lock is active, the controls are locked.

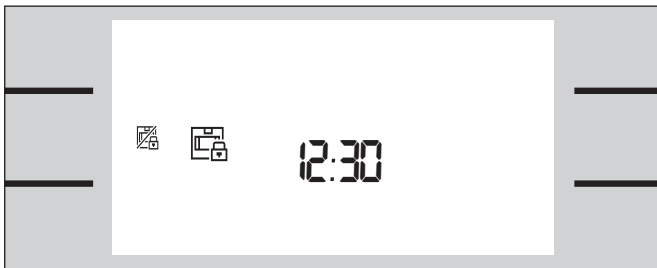
The standby screen and the symbol  appear.





Deactivating the Child Lock

- 1 Touch any key. The symbol  appears beside the centre left key.
- 2 Touch the key  for at least 6 seconds.

The child lock is deactivated. You can operate the appliance as usual.

Note

If you cannot find the  key beside the centre key: Call up the basic settings menu. Select the child lock function. Select “child lock available” .

If the child lock key is no longer required: Call up the basic settings menu. Select the child lock function. Select “child lock not available” .

Safety Deactivation

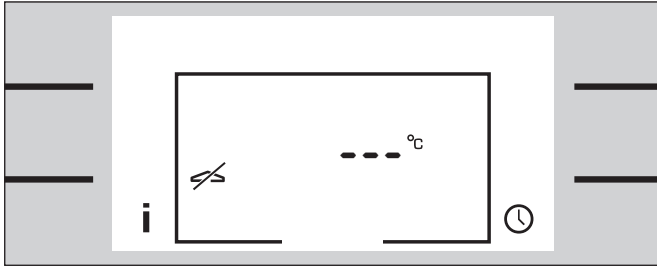

For your protection the appliance has a safety deactivation. The safety deactivation switches off the heat if the oven is left on for more than 12 hours without the controls being touched.





Three dashes appear on the display. Switch the temperature knob off. Then you can operate the appliance as usual.

Changing the Basic Settings

Your appliance has several basic settings.

You can customize these settings:





Turn the temperature knob one position to the right to the light position.

- Call up the basic settings menu with the  key.
- Use the top  or  keys to move between the settings.
- Use the centre keys to change the selected setting. You can change several settings individually without leaving the menu.
- Touch the  key to exit the menu. All settings are saved.

Note

If no key has been touched for 60 seconds the menu disappears. The standby screen appears. All settings are saved.

Example: Changing the Standby Screen

- 1 Call up the basic settings menu by turning the temperature knob one position to the right to the light position. Touch the key next to the  symbol. The menu appears.
- 2 Use the menu key  to select the function standby screen.
- 3 Use the middle keys  or  to select the required setting. The selected screen appears briefly.

Now you can change further settings or exit the menu with the  key.

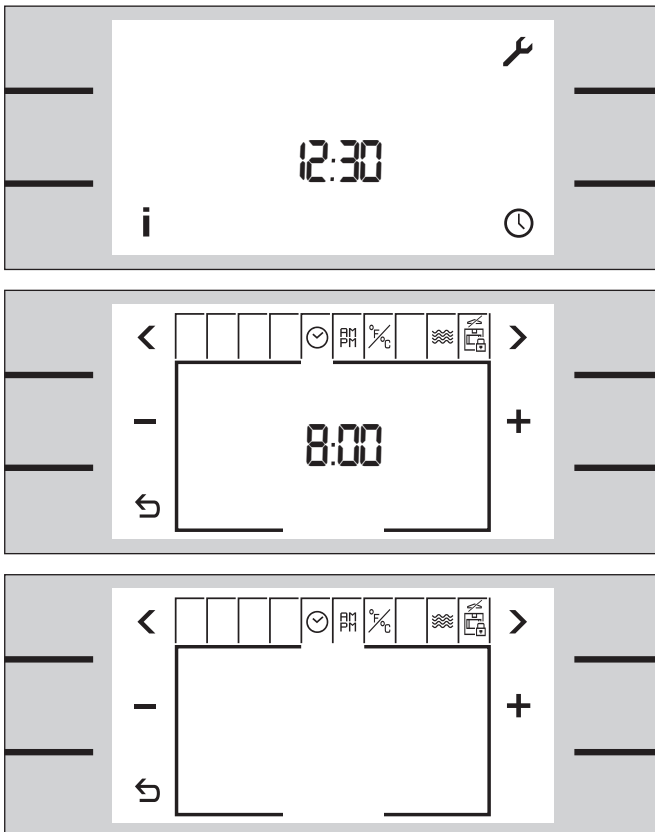

Basic Settings

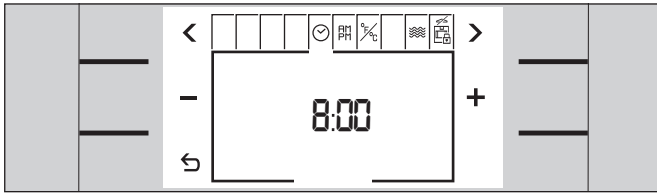

Clock

- Hours / minutes

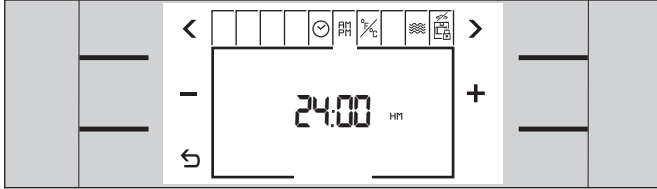

Time format

- 12 hour format (AM/PM) or 24 hour format

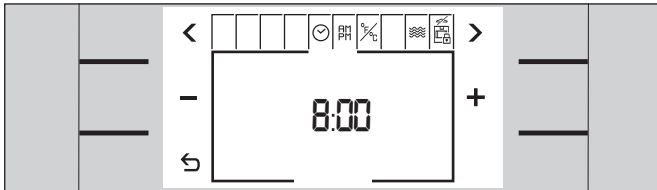

Standby screen

- Clock / empty display

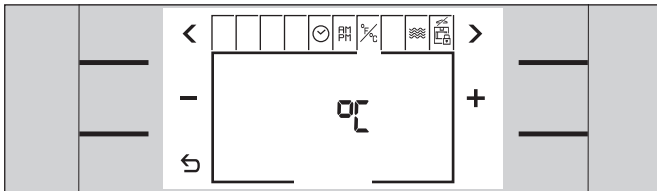

Temperature unit

- °F or °C

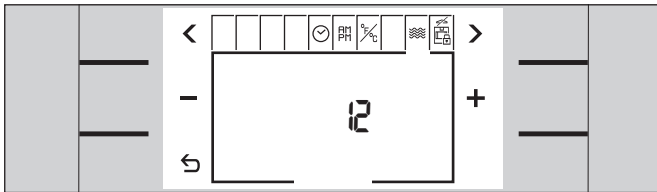

Water hardness

- Set the water hardness between 1 and 18

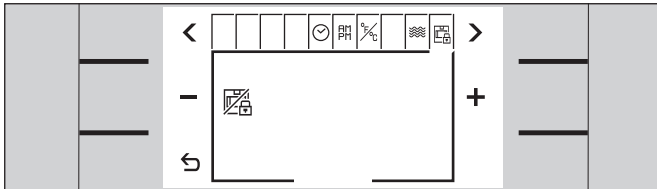

Child lock

- Child lock key not available / available

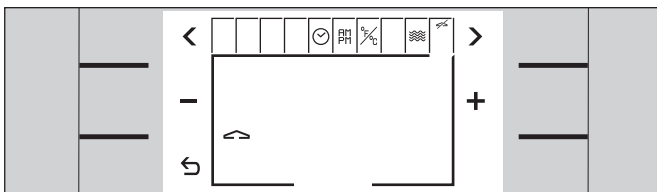

Exhibition mode

The setting ⇄ “exhibition mode not active” must be selected and must not be changed. The appliance does not heat up during exhibition mode 🔒.

You can only change this setting 3 minutes after the appliance has been connected to the electricity.

Care and Manual Cleaning

Safety Notes

⚠ **Warning!** Do not clean the hob using high pressure cleaners or steam jets.

⚠ **Warning, risk of burns!** Before cleaning, wait until the appliance has cooled down.

Oven Interior

Important! Do not spray cleaning agents into the air flap on the top of the oven interior!

Clean the oven interior with a cloth/sponge and a small amount of hot soapy water. Avoid residues burning in. After cleaning, leave the door open until the oven has dried.

For regular care of the stainless steel oven interior we recommend the Gaggenau oven care product which is available through our after sales service or your specialist dealer (order number 667 027). Please observe the included instructions for use of the product.

Do not scrape off baked-in remainders of food. Instead, moisten them with a wet cloth and detergent.

If the oven is heavily soiled use the cleaning aid function for best results.

Do not use non-suitable cleaning agents:

- scouring cleaning agents
- nitro polishing agents
- oven cleaner
- cleaners containing chloride
- abrasive sponges or objects

Cooking Inserts

Clean the cooking inserts in hot soapy water or in the dishwasher.

Soak baked-in remainders of food and clean with a brush.

Racks

You can take the racks out for easier cleaning. Undo the knurled nuts and pull out the racks to the front.

Clean the racks in a dishwasher.

Water Tank

Clean the water tank with hot soapy water. Leave it to dry with the lid opened. Keep the seal in the lid clean and dry after every use.

Dry the slot in the oven after every use.

Glass Front

Clean the glass front with a soft cloth and glass cleaner. Do not wipe the glass front with a soaking wet cloth as water might enter behind the glass.

Do not use aggressive, scouring cleaning agents or glass scrapers. They can scratch the surface and destroy the glass.

A rainbow coloured shimmer may be seen on the front glass. This is the heat resistant coating.

Only clean the display with a soft cloth. Do not wipe the display with a soaking wet cloth as water might enter behind the screen.

Door Seal

Always keep the door seal clean and free of food remains.

Do not use aggressive cleaning agents (e.g. oven cleaner) on the door seal. They can destroy the door seal.



Do not remove the door seal.

Cleaning Function

Stubborn soiling can be loosened using the cleaning function and may then be removed more easily. The cleaning function takes approx. 32 minutes.

Leave the oven to cool down completely before cleaning. Take all accessories out of the oven interior. First clean the evaporating dish to avoid residues burning in.

How to Proceed

- 1 Fill the water tank to the MAX marking with cold water. Do not use distilled water. Fully insert the water tank until it engages.
- 2 Put a small amount of washing up liquid into the evaporating dish on the bottom of the oven interior. Close the oven door.
- 3 Turn the function knob one position to the left. Turn the temperature knob to the left to the special functions. The cleaning menu appears. The duration appears on the display.
- 4 Press  to start. The cleaning starts.
- 5 The second step (rinsing) appears on the display after the time has elapsed.
- 6 Wipe the loosened soiling in the oven interior and in the evaporating dish away with a sponge. Empty the water tank, refill with cold water and insert.
- 7 Close the oven door. Press  to start. The oven rinses.
- 8 After the first rinsing, use a sponge to soak the remaining water from the evaporating dish.
- 9 Close the oven door. Press  to start. The oven rinses again.

After one minute a signal is sounded. The cleaning function has ended. Switch off the temperature knob.

Use a sponge to soak the remaining water from the evaporating dish. Dry the oven interior with a soft cloth.

Note

The duration of the cleaning function cannot be changed. The oven light is off during the cleaning function.

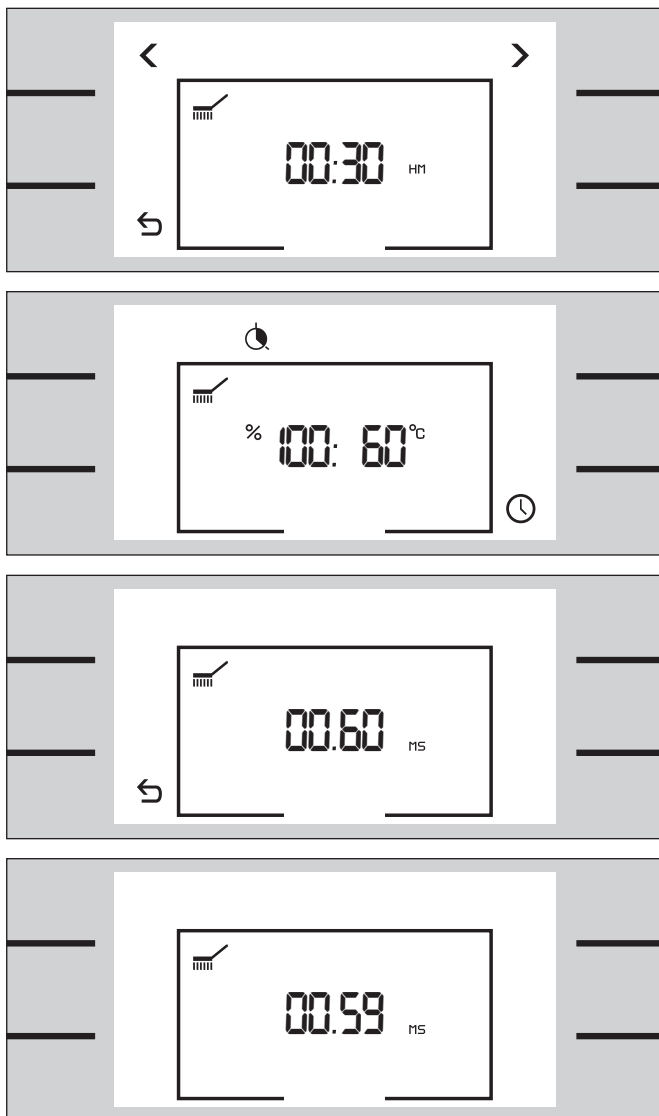

If you want to stop the cleaning function:
Switch off the temperature knob.

If three dashes appear on the display:
Operator error. Check if you have set the functions
and temperature knobs to the correct positions.

Descaling Program

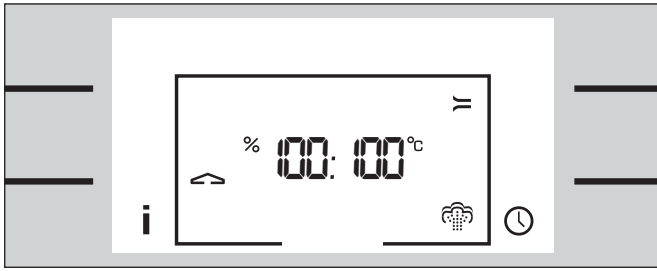

To keep your appliance in good working order, you have to descale it regularly. Descal the oven when the descaling symbol Y appears on the display.

The descaling program consists of three steps – descaling and rinsing twice. The descaling program lasts approx. 32 minutes. Always let the program run until it has ended. The oven light is off during the descaling program.

Use a sponge to empty the evaporating dish between each of the three steps above.

Leave the oven to cool down completely before descaling. Take all accessories out of the oven interior.

Only use our recommended descaler (order number 311 138). Mix the descaling solution according to the manufacturer's instructions. Do not let the descaler come into contact with the frame of the oven.

How to proceed

- 1 Fill the water tank with 350 ml of descaling solution.
- 2 Turn the function knob one position to the left.
- 3 Turn the temperature knob to the left to the special functions. The cleaning menu appears.
- 4 Use the Y menu key to select the Y descaling function. The duration appears on the display.
- 5 Press Y to start.
- 6 The descaling program starts.
- 7 Use a sponge to soak the descaling solution from the evaporating dish after the time has elapsed. Thoroughly rinse the water tank, fill with water and insert.
- 8 Press Y to start. The oven rinses.
- 9 Use a sponge to soak the water from the evaporating dish after the time has elapsed. Close the oven door. Press Y to start. The oven rinses again.

After one minute a signal is sounded. The descaling has ended. Switch off the temperature knob.

After descaling use the Gaggenau oven care product. Please observe the included instructions for use of the product.

Use a sponge to wipe the oven interior and dry with a soft cloth.

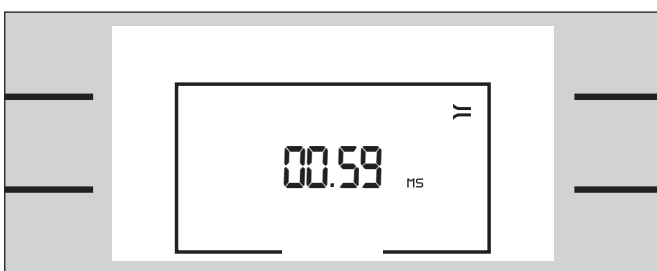
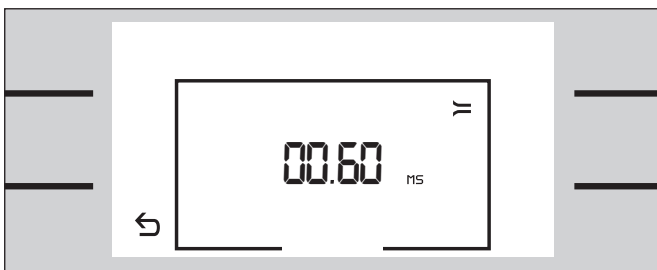
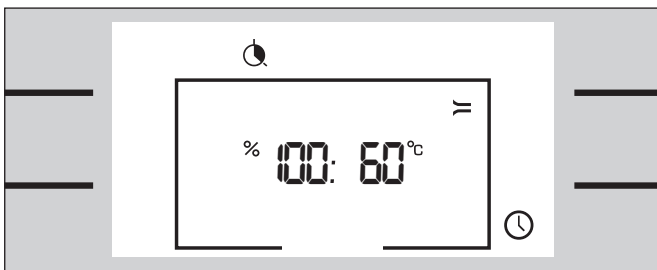

Tip

You can descale the evaporating dish between intervals. Completely fill the evaporating dish with descaling solution and the tank with water. Start the descaling program.

Trouble Shooting

In case of a malfunction first check the household fuses. If the power supply is functioning correctly contact your dealer or Gaggenau after-sales service.

Please specify the E number and FD number of the appliance when calling our after-sales service. You find these numbers on the rating plate of the appliance.

Repairs may only be carried out by authorised technicians, in order to guarantee the electrical safety of the appliance.

⚠ Warning! Incorrect repairs may result in serious injury to the user.

All poles of the appliance must be disconnected from the electricity when being repaired (switch off the household fuse or the circuit breaker in the fuse box).

For technical reasons the lamp cover cannot be removed. Lamp must only be replaced by Gaggenau after-sales service.

Important! Do not remove the lamp cover.

Non compliance with these recommendations results in the warranty coverage becoming invalid.

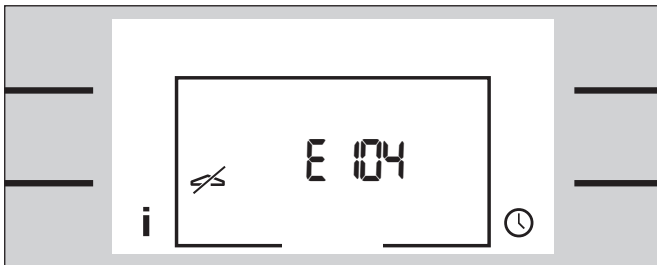

Error Messages

If a malfunction occurs and the appliance does not heat up, an error code will flash on the display.

If *E003*, *E303*, *E 1 15* or *E2 15* flashes on the display the appliance is too hot. Switch off the appliance and let it cool down.

If a different error code flashes on the display call the after-sales service. Please specify the error code and the appliance type. You find the appliance type on the rating plate.

Switch off the temperature knob.

Note:

The short timer and stop clock can still be used.

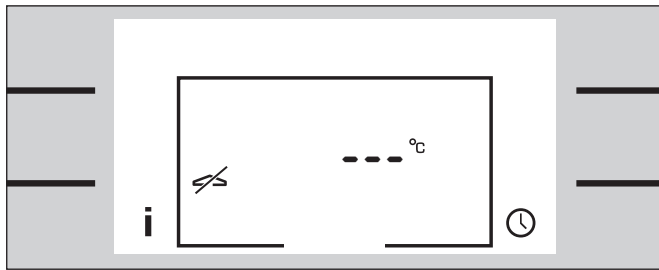

Power Cut

The appliance bridges a power cut of up to 5 minutes. The operation continues.

After a longer power cut the appliance will switch off the operation. The  symbol appears on the display and three dashes instead of the temperature.

Switch off the temperature knob and switch the appliance back on.

The “first settings” menu reappears if the appliance is without electricity for several days. You have to reset the clock.

Note: The basic settings remain stored even if the appliance is without electricity for several days.

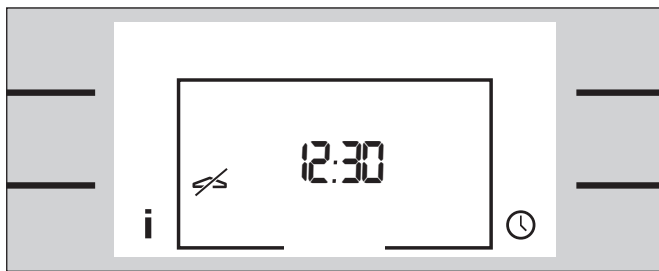

Exhibition Mode

If the  symbol appears on the standby screen, exhibition mode is activated. The appliance does not heat up.

Disconnect the appliance from the electricity for a few seconds (switch off the household fuse or the circuit breaker in the fuse box). Within 3 minutes after reconnecting the appliance, go to the basic settings menu and deactivate exhibition mode.

Gaggenau Hausgeräte GmbH
Carl-Wery-Straße 34
D-81739 München
www.gaggenau.com

9000186423 EB 8812 en

GAGGENAU